

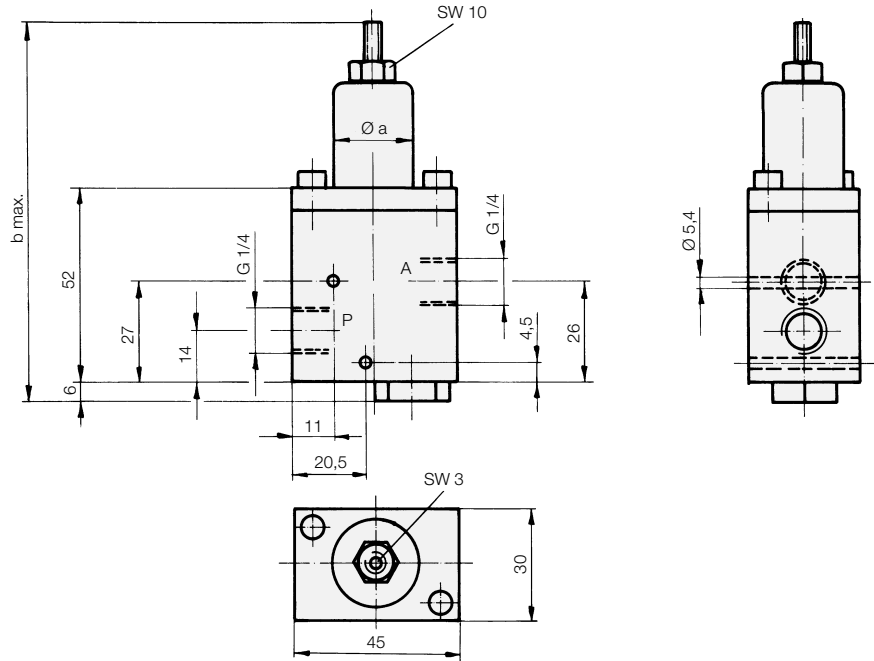

Sequence Valve ND 4
with check valve
max. operating pressure 500 bar

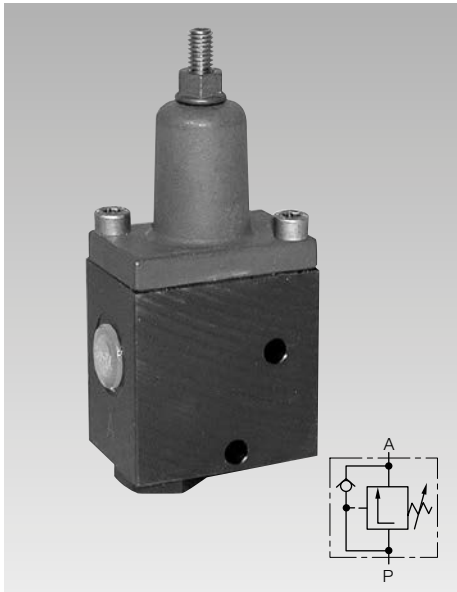

Description

Sequence valves are used in power workholding circuits for pressure dependent sequence control. The compact size allows mounting directly to the clamping fixture, requiring only one pressure line from the power unit to the fixture for single-acting cylinders.

Valve combination see back of the page

Several sequence valves can be manifold mounted together to form a battery with only one common P-line.

Type	directly-controlled spool valve		
Type of mounting	pipes or screws M 5		
Port size	G 1/4	G 1/4	G 1/4
Max. operating pressure [bar]	500	500	500
Max. flow rate [l/min]	8	8	8
Range of adjustment [bar]	10 – 75	10 – 150	100 – 450
Pressure change per rotation [bar]	approx. 6.5	approx. 15	approx. 30
Check valve opening pressure [bar]	0.15	0.15	0.15
Ø a [mm]	22	22	28
b max. [mm]	108.5	108.5	145
Weight [kg]	0.52	0.52	0.64
Part no.	2954 410	2954 420	2954 440

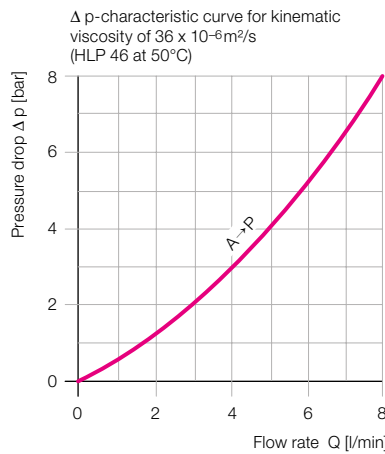

Application example

The workpiece is to be positioned and clamped in the fixture with hydraulic clamping cylinders.

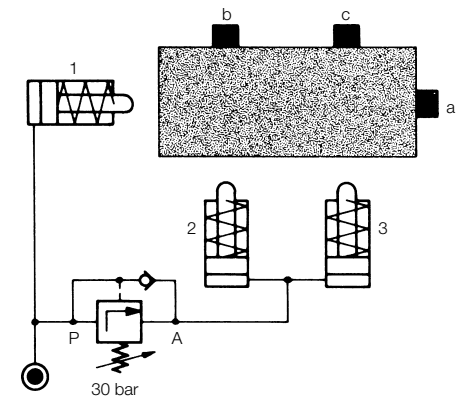

Clamping sequence

1. Cylinder 1 pushes workpiece against stop a.
2. Pressure rises to 30 bar, sequence valve opens.
3. Cylinder 2 and 3 extend and push the workpiece against stop b and c.
4. Oil pressure rises uniformly in all cylinders, because of the throttle-free passage of the opened sequence valve.

Sequence valves for manifold mounting

These sequence valves are also available for manifold mounting. Hydraulic oil is supplied and returned through drilled channels in the fixture body.

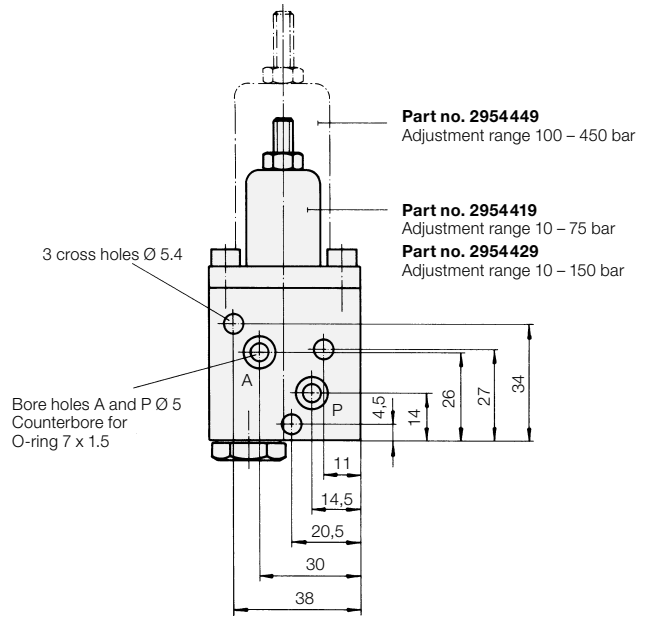
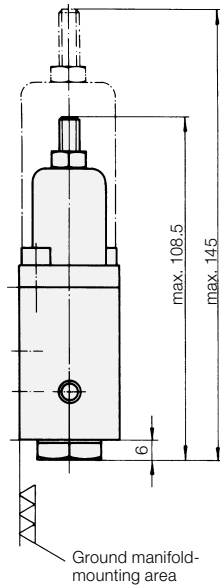

Range of adjustment [bar]	Part no.
10 – 75	2954419
10 – 150	2954429
100 – 450	2954449
Spare O-ring	3000342

Sequence valve battery combination

These batteries consist of one input valve and up to five series valves. Only one pressure line is required to port P of the input valve.

The other valves are interconnected by an internal passage, sealed with an O-ring between each valve.

To assure optimum operation it is required to adjust settings between adjacent valves of the type 295442X not below a pressure differential of 25 bar, and for the type 295444X not below 50 bar.

Description	Range of adjustment [bar]	Part no.
Input valve	10 – 150	2954427
Input valve	100 – 450	2954441
Series valve	10 – 150	2954428
Series valve	100 – 450	2954442

Description	Number of valves	Dimensions	Part no.
Tie rod	2	M 5 x 72	3619029
Tie rod	3	M 5 x 102	3619031
Tie rod	4	M 5 x 132	3619032
Tie rod	5	M 5 x 162	3619033
Tie rod	6	M 5 x 192	3619034

Example of ordering

Battery combination consisting of 3 valves with an adjustment range of 10–150 bar and 1 valve with an adjustment range of 100–450 bar.

	Bestell-Nr.
1 off input valve	2954427
2 off series valve	2954428
1 off series valve	2954442
2 off tie rod M 5 x 132	3619032
Spare O-ring	3000343

Required plugs, O-rings and hexagon nuts are included.

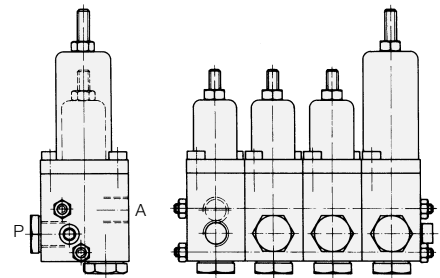

Hydraulic circuit diagram

Sequence control for 5 single-acting clamping cylinders.

