

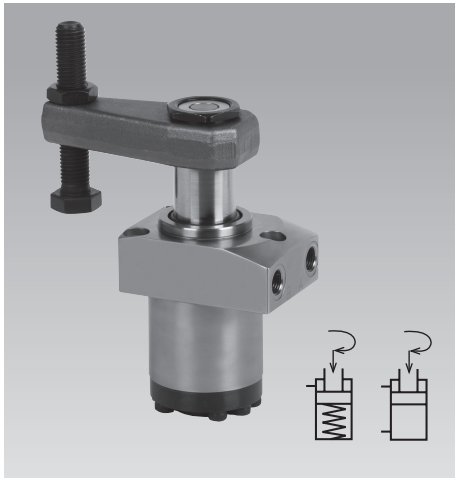

Swing Clamps with Overload Protection Device

top flange, single and double acting,
 max. operating pressure 500 bar



Hydraulic connecting possibilities

Pipe thread

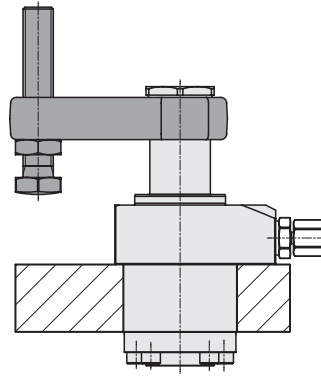

Manifold mounting with O-ring sealing

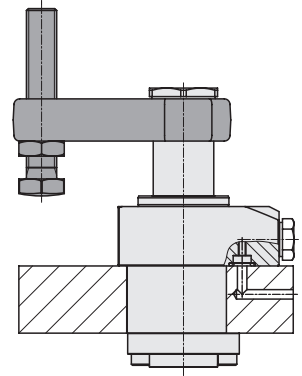

Application

Hydraulic swing clamps are used for clamping of workpieces when it is essential to keep the clamping area free of straps and clamping components for unrestricted workpiece loading and unloading.

Function

This hydraulic clamping element is a pull-type cylinder where a part of the total stroke is used to swing the piston.

Swing direction

The units are available with clockwise and counterclockwise swing motion or without swing motion (0°). Starting from the off-position.

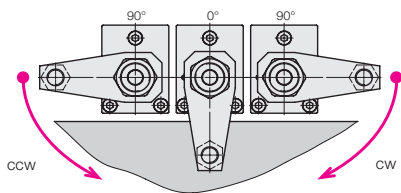

Standard swing angles

are 45°, 60° and 90° ±2°.

Special angles on request.

Other variants, as e.g. versions with metallic wiper on request

0°-Version

Use as pure pull-type cylinder with a piston which is secured against torsion and which allows eccentric load as per clamping force diagram.

Application example

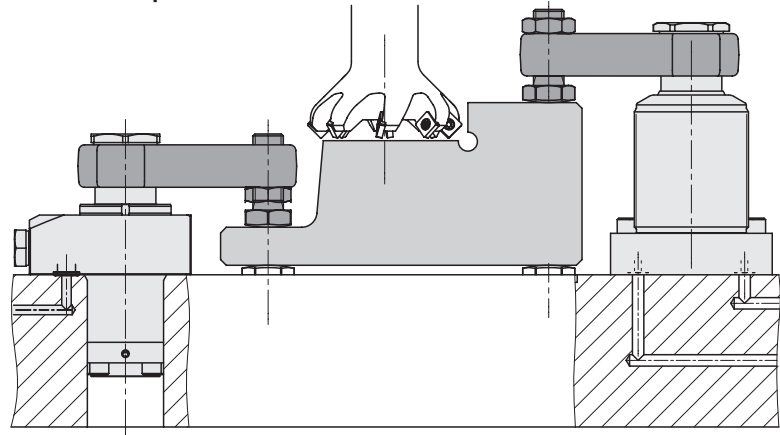

Overload protection device

An integrated mechanical overload protection device prevents damage to the swing mechanism when striking an object within the 90° rotation, clamping or unclamping alike, or in case of incorrect mounting of the clamping arm.

Metallic wiper
 optional

Material

By nitrating wear is reduced and protection against corrosion increased.

Piston material:	High alloy steel
Cylinder body:	High alloy steel
Seals:	NBR
Wiper:	FKM

Note!

Operating conditions, tolerances and other data see data sheet A 0.100.

When using single-acting swing clamps, it is absolutely necessary to follow the instructions for venting of the spring area on data sheet G 0.110.

Further notes see Page 3.

Option: metallic wiper

These swing clamps are also delivered with mounted metallic wiper that protect the subjacent FKM wiper against swarf (see page 2 and 3).

Dimensions Technical Data

Accessory:
Clamping arm
assembly, complete
for max. 200 bar

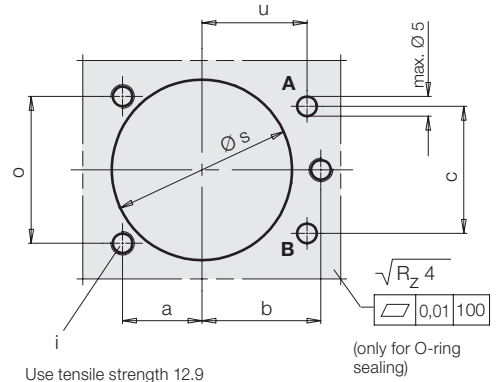
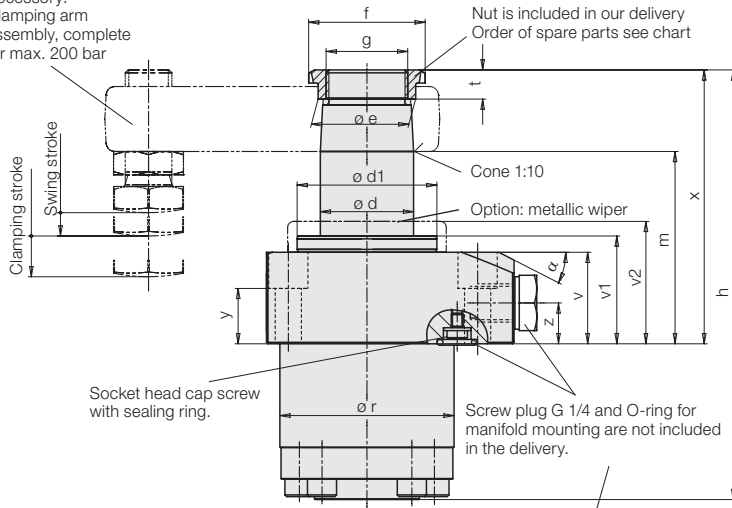

- A: Clamping
- B: Venting (single acting)
- B: Unclamping (double acting)

The swing clamps will be delivered ready for the connection of pipes.

Manifold mounting (drilled channels)

Single acting

Screw in 1 screw plug G 1/4 (part no. 3610264) in port A and remove socket head cap screw with sealing ring. Insert 1 O-ring 10x2 (part no. 3000347) in the counterbore.

If venting of the spring area at port B shall also be effected through drilled channels: Replace screw plug with air filter by screw plug G 1/4. Remove socket head cap screw with sealing ring and insert O-ring 10x2 (part no. 3000347) in counterbore.

Double acting

Screw in 2 plugs G 1/4 (part no. 3610264).

Remove 2 socket head cap screws with sealing ring. Insert 2 O-rings 10x2 (part no. 3000347) in the counterbore.

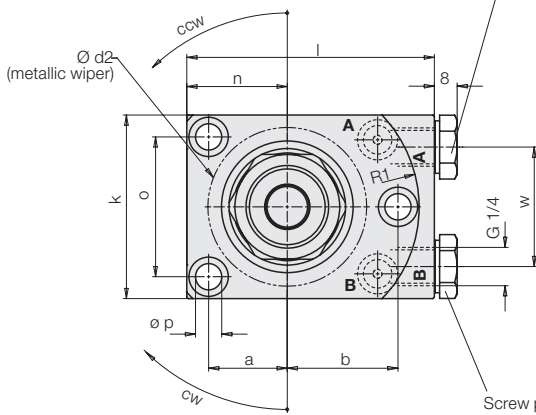

Effective clamping force F_{Sp} as function of operating pressure p

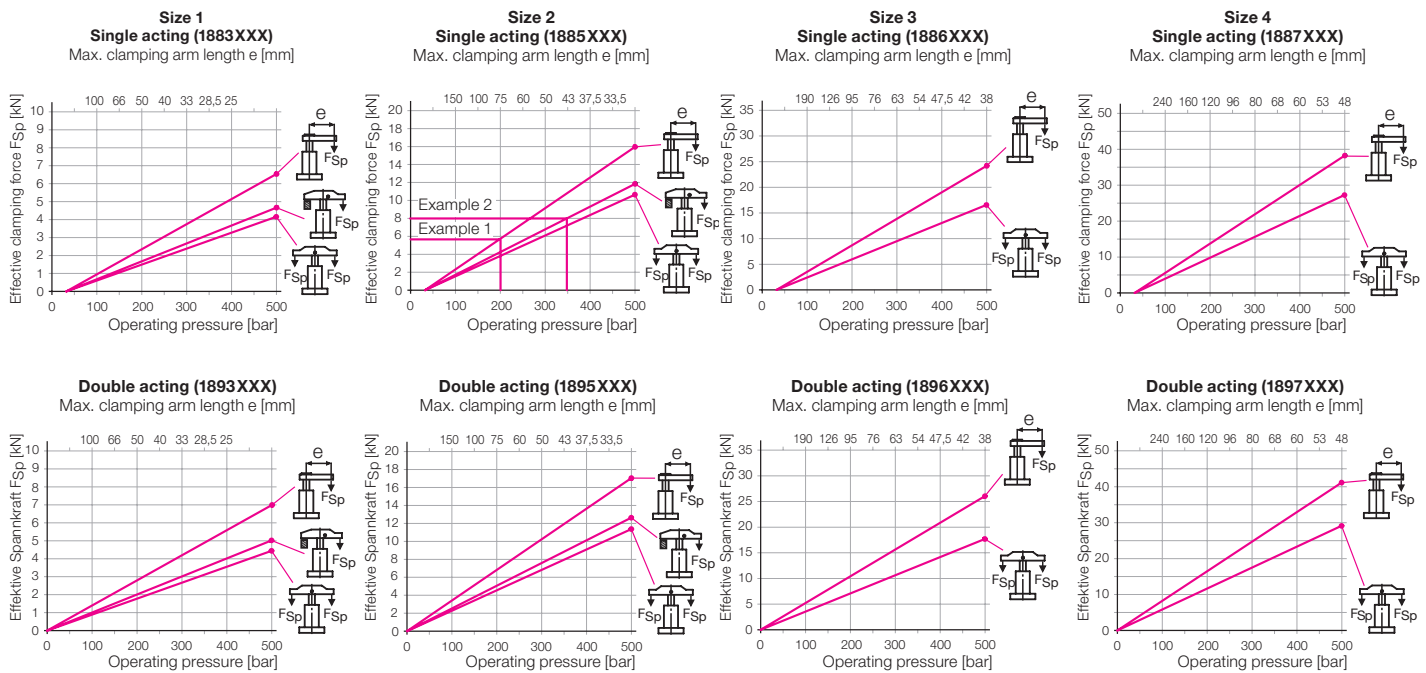

Note:

The clamping force of single-acting swing clamps is reduced by the opposite-directed spring return force.

For this reason the clamping force is slightly lower than that of double-acting swing clamps.

Example 1: 1885 103 single acting.

An operating pressure p of 200 bar in connection with standard clamping arm 0354003 of max. arm length $L = 75$ mm results in an effective clamping force F_{Sp} of 5.8 kN.

Example 2: 1885 103 single acting.

For a desired effective clamping force F_{Sp} of 8 kN and use of a swing clamp 1885 103 with a standard clamping strap 0354002 an operating pressure p of 345 bar is required.

Accessories

Dimensions for special clamping arms

Swing clamp	a	b	Ø c	Ø d ^{+0,10 +0,05}	e	f	g	Ø h _{f7}
18X3XXX	16	4	24	19,8	10	21	M 18x1,5	20
18X5XXX	23	5	34	31,8	12	28	M 28x1,5	32
18X6XXX	28	5	46	39,8	12	34	M 35x1,5	40
18X7XXX	34	6	56	49,8	13	40	M 45x1,5	50

Clamping arm, max. 300 bar

Swing clamp	a	b	c	d	e	f	g	h	i	Weight [kg]	Part no.
18X3XXX	51,5	21	32	14	33,5	16	15,5	14,5	7	0,11	3548 238
18X5XXX	76	28	46	25	50	23	22,5	19	7	0,3	3548 236
18X6XXX	100	34	66	39	64	33	28	23	7	0,84	3548 301
18X7XXX	123	40	75	39	82,5	37,5	34	27	8	1,3	3548 302

Material: 42CrMo4

Clamping arm assembly, complete, max. 200 bar

Swing clamp	a	b	c	d	e	f	g	h max.	h min.	Weight [kg]	Part no.
18X3XXX	75	16	32	16	50	16	M10	64	6	0,2	0354 001
18X5XXX	115	23	48	22	75	25	M16	79	9	0,7	0354 003
18X6XXX	140	28	60	28	95	30	M16	79	9	2,0	0354 042
18X7XXX	178	34	78	40	120	40	M20	98	12	2,55	0354 005

Swing clamp	a	b	c	d	f	Weight [kg]	Part no.
18X3XXX	75	16	32	16	16	0,18	3921 016
18X5XXX	115	23	48	22	25	0,65	3921 017
18X6XXX	140	28	60	28	30	1,85	3921 021
18X7XXX	178	34	78	40	40	2,3	3921 018

Material: 42CrMo4

Clamping strap assembly, complete, with carrier, max. 500 bar

Swing clamp	a	b	c	d	e	f	g	h max.	h min.	i	k	Weight [kg]	Part no.
18X3XXX	122	30	1,5	44	60	45	M10	64	6	53	14,5	0,57	0354 000
18X5XXX	185	45	2	58,5	83	75	M16	79	9	87	21	1,58	0354 002

Material: GGG-40

Carrier for special clamping strap

Swing clamp	a	b	c	d	e	f	g ^{H7}	h	Weight [kg]	Part no.
18X3XXX	46	26	32	16	7,5	14,5	8	16	0,08	3542 093
18X5XXX	59	32	40	23	13	21	10	22	0,16	3542 094
18X6XXX	82	44,5	58	28	17	28	12	34	0,5	3542 132
18X7XXX	90	56	68	34	21	33	14	36	0,65	3542 096

Material: 42CrMo4

Double clamping arm assembly, complete, with carrier, max. 500 bar

Swing clamp	a	b	c	Ø d	e	f min.	f max.	g	SW	Weight [kg]	Part no.
18X3XXX	138	59	28,5	20	60	10	64	M 10	5	0,83	0354 131
18X5XXX	196	75	38	32	83	15	79	M 16	8	2,11	0354 132
18X6XXX	216	85	47	40	92	15	79	M 16	8	3,17	0354 133
18X7XXX	236	105	56	50	100	19	98	M 20	8	5,24	0354 134

Material: GGG-40

Carrier, complete with threaded bolt and spring clamping elements

Swing clamp	a±0,1	b	c	Ø d	e	Ø f ^{g6}	g*	SW	Part no.
18X3XXX	43	16	7,5	20	9	10	21,5	5	0354 141
18X5XXX	55	23	11	32	11	16	29	8	0354 142
18X6XXX	63	28	15	40	12	18	35	8	0354 143
18X7XXX	77	34	17	50	15	20	41	8	0354 144

* Stop surface for spring elements

Material: 42CrMo4