

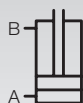

Universal Cylinders

double acting, max. operating pressure 400 bar



Application

These cylinders are used as lifting and clamping cylinders in machine and fixture building. They can be inserted in the smooth through-hole and fixed in different levels by means of a locking ring.

Description

Large clamping force range. Radial and axial oil ports. High degree of sealing. Wiper as protection of contamination, swarf, and coolants.

Material

Piston and piston rod one-piece components are hardened and ground. Cylinder of high alloy steel, black oxidized.

Accessories

Contact bolts see data sheet G 3.800.

Important notes

Operating conditions, tolerances and other data see data sheet A 0.100.

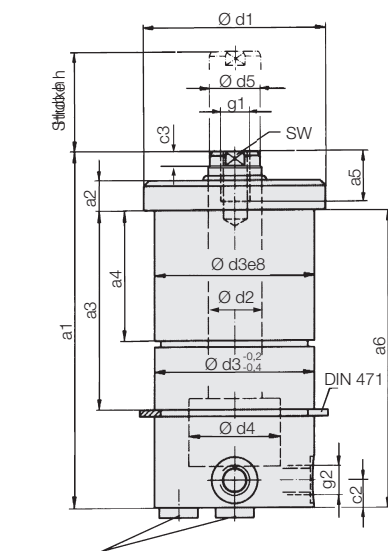

Change plugs in case of axial connection

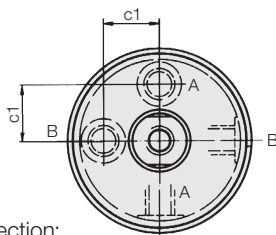

Oil connection:

A = Piston side

B = Rod size

Application examples

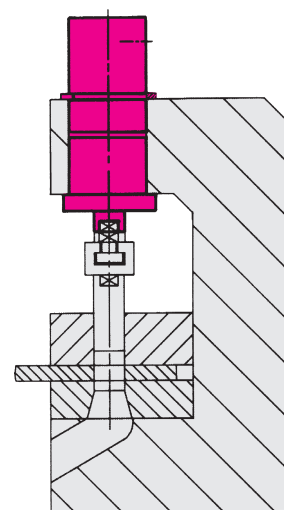
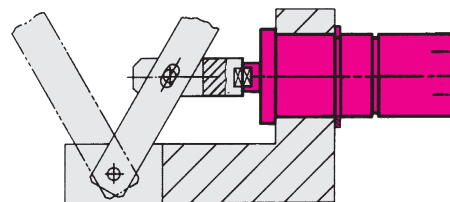

Piston Ø d4	[mm]	25	32	40	50	63
Rod Ø d2	[mm]	14	18	22	28	36
Stroke h	[mm]	32	40	50	64	64
Force to push 100 bar	[kN]	4.9	8	12.5	19.6	31.1
at 400 bar	[kN]	19.6	32	50	78.4	124.4
Force to pull 100 bar	[kN]	3.3	5.5	8.7	13.5	21
at 400 bar	[kN]	13.2	22	34.8	54	84
Oil volume per 1 mm piston stroke						
Piston side	[cm ³]	0.5	0.8	1.3	2.0	3.1
Rod side	[cm ³]	0.4	0.6	0.9	1.4	2.1
a1	[mm]	122	133	147	167	186
a2	[mm]	10	10	12	12	15
a3	[mm]	65.1	70.1	80.1	80.1	100.1
a4	[mm]	45.1	45.1	50.1	50.1	60.1
a5	[mm]	12	16	18	20	20
a6	[mm]	100	110	120	136	150
c1	[mm]	14.5	18	23	28	34
c2	[mm]	12.5	12.5	10.5	10.5	13
Ø d1	[mm]	56	66	76	90	105
Ø d3	[mm]	50	58	68	80	95
Ø d5 x c3	[mm]	13x5,5	17x6,5	21x8,5	27x10,5	35x12
g1	[mm]	M 8	M 10	M 12	M 16	M 20
g2		G 1/4	G 1/4	G 1/4	G 1/4	G 3/8
SW	[mm]	11	15	19	24	30
Weight	[kg]	1.7	2.4	3.6	5.7	8.7
Part no.		5112303	5112403	5112503	5112603	5112703

Article available on request