

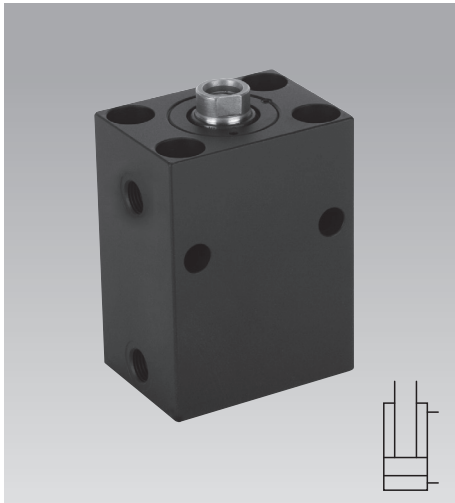

Block Cylinders

double acting, max. operating pressure 500 bar



Advantages

- 11 sizes each with up to 5 stroke lengths available
- Large range of diameter
Piston Ø 16 up to 200 mm
- Large range of stroke 8 up to 200 mm
- Large range of force
2 kN for piston Ø 16 mm and 100 bar
1570 kN for piston Ø 200 mm and 500 bar
- Large retention force
- Compact block design
- Many fixing possibilities
- Many connecting possibilities
- Case-hardened piston rod
- Alternatively NBR or FKM seals and wiper
- Operating temperature up to 200 °C with FKM seals
- Minimum leakage
- Maintenance free

Application

Double-acting block cylinders can be used universally for all hydraulically-operated linear movements.

- Positioning
- Clamping
- Supporting
- Locking
- Bending
- Riveting
- Punching
- Moving
- Opening and closing
- Locking and unlocking
- Lifting and lowering
- Pushing and pulling

Function

The double-acting functioning allows a force generation in both axial directions (force to push and to pull). This guarantees a high function safety as well as exactly calculable and repetitive times required for the stroke.

Material

Cylinder housing: high alloy steel, black oxide*
Piston: case-hardening steel, hardened and ground

O-rings and wipers:

NBR = nitrile-butadiene rubber
Temperature range: -25 up to +100 °C
FKM = fluor caoutchouc
Temperature range: -15 up to +200 °C

Glydrings and back-up rings:

PTFE = polytetrafluor ethylene
Temperature range: -45 up to +200 °C

Hydraulic fluid: see data sheet A 0.100

Special versions for other hydraulic fluids and operating temperatures up to +250 °C are available on request.

* from size 1549 black matt lacquered

Design

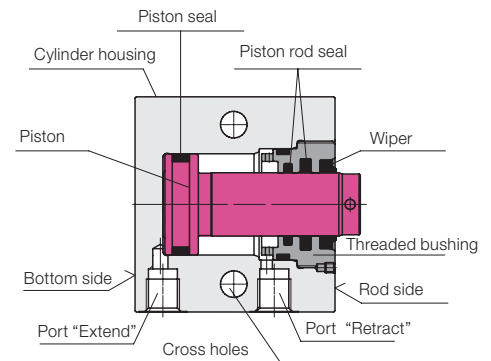

Fixing possibilities

Possible mounting holes

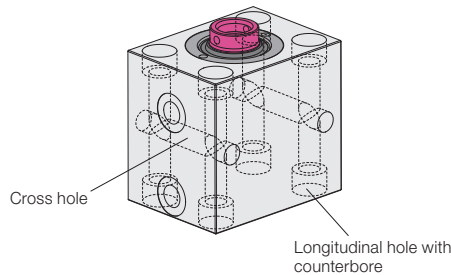

● Broad side

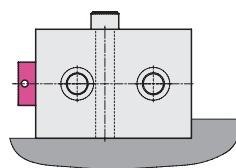

15XXX 0
1

● Rod side

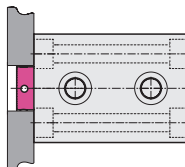

15XXX 5
6

● Bottom side

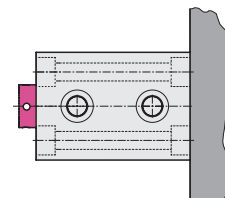

15XXX 5
6

Hydraulic connecting possibilities

Pipe thread

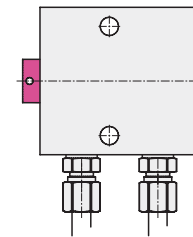

15XXX 0
1
5
6

Flange with O-ring sealing

● Broad side

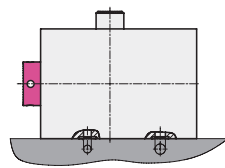

15XXXX K
L

● Rod side

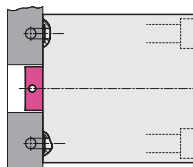

15XXXX S

● Bottom side

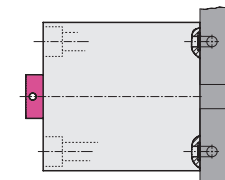

15XXXX B

Pipe thread

16 up to 100 mm stroke

2 cross holes

15XXX 0 (NBR)
1 (FKM)

2 cross holes and
4 longitudinal holes

15XXX 5 (NBR)
6 (FKM)

160 and 200 mm stroke

4 cross holes and
4 longitudinal holes
FKM seals

15XX 210 (160 stroke)
211 (200 stroke)

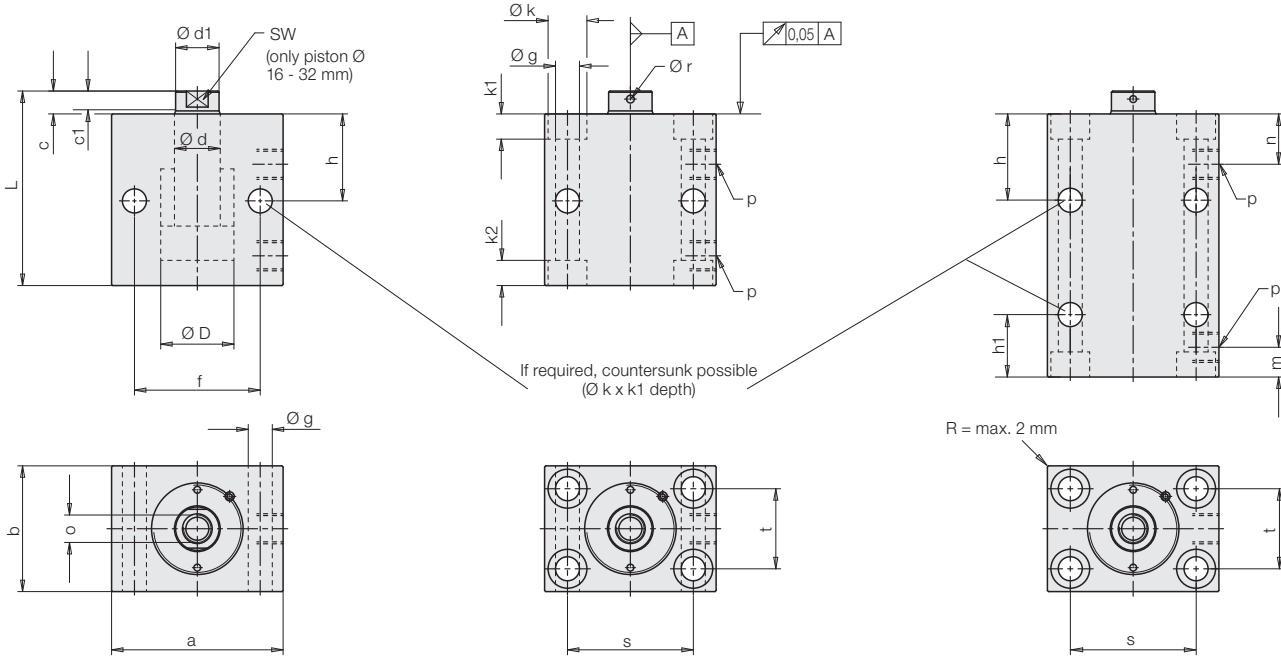

Piston Ø D	[mm]	16	25	32	40	50	63	80	100	125	160	200
Rod Ø d	[mm]	10	16	20	25	32	40	50	63	80	100	125

16 up to 100 mm stroke X = identification code for bore holes and seals → see above

Stroke ±0.6	[mm]	16	20	25	25	25	30	32	40	40	40	50
Total length L ±0.5	[mm]	62	71	85	89	100	116	131	145	166	190	238
Weight approx.	[kg]	0.9	1.4	2.2	2.9	4.8	8	15	24.0	39	85	143
Part no.		1541 10X	1543 10X	1544 10X	1545 10X	1546 10X	1547 10X	1548 10X	1549 10X	1550 10X	1551 00X	1552 00X*
Stroke ±0.6	[mm]	50	50	50	50	50	63	80	-	-	-	-
Total length L ±0.5	[mm]	97	101	110	114	125	149	179	-	-	-	-
Weight approx.	[kg]	1.4	2	2.7	3.6	6	10	20	-	-	-	-
Part no.		1541 16X	1543 16X	1544 16X	1545 16X	1546 16X	1547 17X	1548 18X	-	-	-	-
Stroke ±0.6	[mm]	100	100	100	100	100	100	100	100	100	100	100
Total length L ±0.5	[mm]	150	151	160	164	175	186	199	205	226	250	288
Weight approx.	[kg]	2	2.8	4.1	5.6	8.3	13.2	22.8	37	54	110	183
Part no.		1541 19X	1543 19X	1544 19X	1545 19X	1546 19X	1547 19X	1548 19X	1549 19X	1550 19X	1551 09X	1552 09X*

160 and 200 mm stroke

Stroke ±0.6	[mm]	-	160	160	160	160	160	160	160	160	160	160
Total length L ±0.5	[mm]	-	214	223	227	238	250	263	269	290	314	352
Weight approx.	[kg]	-	4.2	6.1	8	11.7	19.0	33	50	72	129	235
Part no.		-	1543 210	1544 210	1545 210	1546 210	1547 210	1548 210	1549 210	1550 210	1551 210	1552 210
Stroke ±0.6	[mm]	-	-	200	200	200	200	200	200	200	200	200
Total length L ±0.5	[mm]	-	-	263	267	278	290	303	309	330	354	392
Weight approx.	[kg]	-	-	7.2	9.3	13	22	36	60	82.5	147	265
Part no.		-	-	1544 211	1545 211	1546 211	1547 211	1548 211	1549 211	1550 211	1551 211	1552 211

* Only identification code 5 or 6 available

Dimensions

Technical data • Important notes

Size		1541	1543	1544	1545	1546	1547	1548	1549	1550	1551	1552
Piston Ø D	[mm]	16	25	32	40	50	63	80	100	125	160	200
Rod Ø d	[mm]	10	16	20	25	32	40	50	63	80	100	125
Force to push at	100 bar [kN]	2.0	4.9	8.0	12.6	19.5	31.2	50.4	78.4	122.7	201	314
	500 bar [kN]	10.0	24.5	40.2	62.8	98.5	156.0	252.0	392.0	613.5	1005	1570
Force to pull at	100 bar [kN]	1.2	2.9	4.9	7.7	11.6	18.6	30.6	47.4	72.4	122.5	191
	500 bar [kN]	6.1	14.5	24.5	38.3	57.9	93.0	153.2	236.8	362	612.6	957
Oil volume/ stroke to extend[cm ³]		2.01	4.91	8.05	12.56	19.63	31.17	50.26	78.54	122.7	201	314
	10 mm stroke to retract[cm ³]	1.2	2.9	4.9	7.7	11.6	18.6	30.6	47.4	72.4	122.5	191
a	[mm]	60	65	75	85	100	125	160	200	230	300	380
b	[mm]	35	45	55	63	75	95	120	150	180	230	300
c	[mm]	6 (7)*	7	10	10	10	14	14	15	16 ±0.3	22 ±0.3	28 ±0.3
Ø d1 x c1	[mm]	9.2x3.7	15x5	19x7.8	24x7.1	30.5x6.5	38.7x9.2	48x9.2	61x10.7	78x11.2	97x15.8	122x17.8
f	[mm]	30	50	55	63	76	95	120	158	180	230	300
Ø g	[mm]	6.5	8.5	10.5	10.5	13	17	21	25	32	39	52
h	[mm]	30	33	38	40	44	50	60	64	82	92	112
h1	[mm]	24.5	26	27	27	30	41	47	54	66	77	95
Ø k	[mm]	11	13.5	17	17	20	26	33	40	48	57	76
k1	[mm]	7	9	11	11	13	17	21.5	25.5	32	38	50
k2	[mm]	4	9	11	11	13	17	21.5	25.5	32	38	50
m	[mm]	11	11	11	11	13	17	21	25	31	39	51
n	[mm]	16.5	18	22	24	27	26	34	35	47	55	68
o x thread depth	[mm]	M6x12	M10x15	M12x15	M16x25	M20x30	M27x40	M30x40	M42x60	M48x70	M56x80	M72x100
p		G1/4	G1/4	G1/4	G1/4	G1/4	G1/2	G1/2	G1/2	G1/2	G1/2	G3/4
Ø r	[mm]	–	–	–	4	4	4	5	6	8	10	12
s	[mm]	40	50	55	63	76	95	120	158	180	230	300
t	[mm]	22	30	35	40	45	65	80	108	130	160	220
SW	[mm]	8	13	17	–	–	–	–	–	–	–	–
u ± 0.05	[mm]	1.1	1.1	1.1	1.1	1.1	1.5	1.5	1.5	1.5	1.5	–
Ø v1 extend	[mm]	3.5	4	5	6	6	8	8	8	8	10	–
Ø v2 retract	[mm]	3.5	4	4.5	4.5	6	6	8	8	8	10	–
w + 0.2	[mm]	9.8	9.8	9.8	9.8	10.8	13.8	13.8	13.8	13.8	15.8	–
x	[mm]	7	7.5	10	10	13	16	21	25	31	39	–
y	[mm]	20.5	21	25	27	29.5	32	39	40	47	55	–

General tolerances as per DIN ISO 2768-mH
* 7 mm for 1541 16X and 1541 19X

Important notes

The block cylinders designed for industrial applications to transform hydraulic pressure to a linear movement and /or force. They can generate very high forces. The fixture or machine must be in the position to compensate the forces. In the effective area of the clamping bolt there is the danger of crushing. The manufacturer of the fixture or the machine is obliged to provide effective protection devices.

Mounting

In principle, screws of tensile strength 8.8 can be used to secure the block cylinders.

Support

If block cylinders are fastened with screws across the cylinder axis, they must be supported above a specific operating pressure.

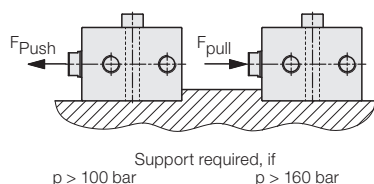

The support only has to be a few millimetres high.

As an alternative to a support, the housing of the block cylinders can be provided with a keyway, that transfers the cylinder forces to the baseplate surface via a key. (see page 5 “standard variants”)

Admissible dynamic load

This block cylinder line is not equipped with stroke end cushioning, i.e. a weight m fixed to the piston will move with speed v against the internal stop without braking. Above all in extending direction, the threaded bushing is overloaded and the operating safety is jeopardised.

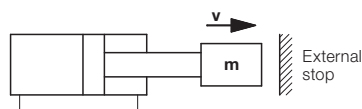

At piston speeds higher than 0.05 m/s and a weight that exceeds the own weight of the block cylinder, a cylinder with stroke end cushioning has to be used or the cylinder movement must be effected against an external stop. This is also valid for punching applications.

Admissible side loads

Side loads stress the guides for the piston and piston rod of the cylinder and thereby cause a reduction in working life and leakages leading to the destruction of the cylinder.

Under no circumstances must the cylinder side load exceed 3% of the cylinder force at maximum operating pressure (up to 50 mm stroke). In the case of longer strokes please contact us.

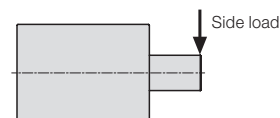

Accessory - Contact bolts

As accessory different contact bolts and coupling pins are available. See data sheet G.3.800.

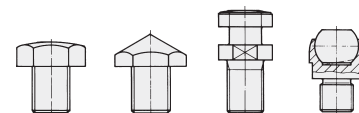

For further application instructions see data sheet A.0.100 and program summary “Block Cylinders”.

Flange with O-ring sealing

Broad side K

16 up to 40 mm stroke
2 cross holes
15XX X00K (NBR)
15XX X01K (FKM)

Broad side L

50 up to 100 mm stroke
4 cross holes
15XX XX0L (NBR)
15XX XX1L (FKM)

Rod side S

16 up to 100 mm stroke
4 longitudinal holes
15XX XX5S (NBR)
15XX XX6S (FKM)

Bottom side B

16 up to 100 mm stroke
4 longitudinal holes
15XX XX5B (NBR)
15XX XX6B (FKM)

160 and 200 mm stroke
4 cross holes and FKM seals
15XX 210L (160 stroke)
15XX 211L (200 stroke)

160 and 200 mm stroke
4 longitudinal holes and FKM seals
15XX 210S (160 stroke)
15XX 211S (200 stroke)

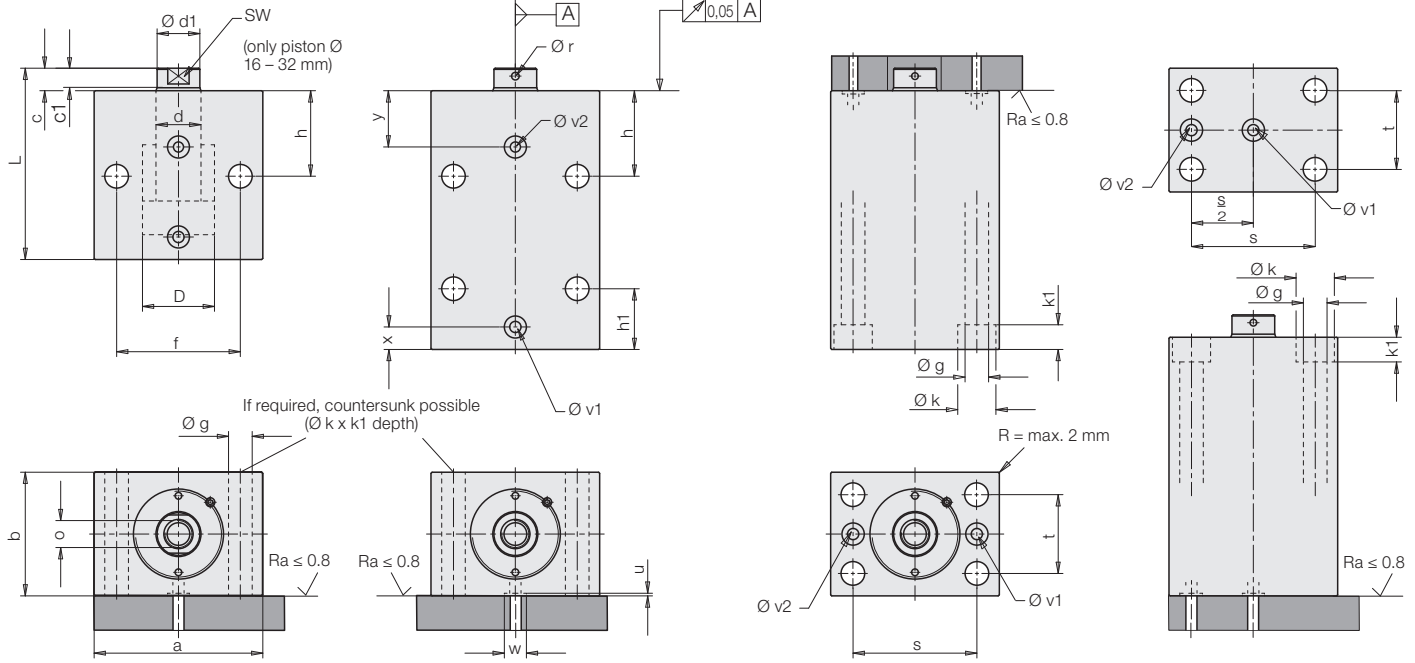

Piston Ø D	[mm]	16	25	32	40	50	63	80	100	125	160
Rod Ø d	[mm]	10	16	20	25	32	40	50	63	80	100

16 up to 100 mm stroke XX = identification codes for sealing material and manifold-mounting area → see above

Stroke ±0.6	[mm]	16	20	25	25	25	30	32	40	40	40
Total length L +0.5/-0.8	[mm]	62	71	85	89	100	116	131	145	166	190
Weight approx.	[kg]	0.9	1.4	2.2	2.9	4.8	8.0	15.0	24.0	39.0	85.0
Part no.		154110XX	154310XX	154410XX	154510XX	154610XX	154710XX	154810XX	154910XX	155010XX	155100XX
Stroke ±0.6	[mm]	50	50	50	50	50	63	80	-	-	-
Total length L +0.5/-0.8	[mm]	97	101	110	114	125	149	179	-	-	-
Weight approx.	[kg]	1.4	2.0	2.7	3.5	6.0	10.0	20.0	-	-	-
Part no.		154116XX	154316XX	154416XX	154516XX	154616XX	154717XX	154818XX	-	-	-
Stroke ±0.6	[mm]	100	100	100	100	100	100	100	100	100	100
Total length L +0.5/-0.8	[mm]	150	151	160	164	175	186	199	205	226	250
Weight approx.	[kg]	2.0	2.8	4.1	5.6	8.3	13.2	22.8	37	54	110
Part no.		154119XX	154319XX	154419XX	154519XX	154619XX	154719XX	154819XX	154919XX	155019XX	155109XX

160 and 200 mm stroke X = identification code for manifold-mounting area → see above

Stroke ±0.6	[mm]	-	160	160	160	160	160	160	160	160	160
Total length L +0.5/-0.8	[mm]	-	214	223	227	238	250	263	269	290	314
Weight approx.	[kg]	-	4.2	6.1	7.8	11.7	19.0	33.0	50.0	72.0	128.0
Part no.		-	1543210X	1544210X	1545210X	1546210X	1547210X	1548210X	1549210X	1550210X	1551210X
Stroke ±0.6	[mm]	-	-	200	200	200	200	200	200	200	200
Total length L +0.5/-0.8	[mm]	-	-	263	267	278	290	303	309	330	354
Weight approx.	[kg]	-	-	7.2	9.3	13.0	22.0	36.0	60.0	83.0	146.0
Part no.		-	-	1544211X	1545211X	1546211X	1547211X	1548211X	1549211X	1550211X	1551211X

O-rings for manifold-mounting area: (included in the delivery)

Dimensions	[mm]	7x1.5	7x1.5	7x1.5	7x1.5	8x1.5	10x2	10x2	10x2	10x2	12x2
Part no.	NBR	3000342	3000342	3000342	3000342	3000343	3000347	3000347	3000347	3000347	3000349
Part no.	FKM	3001077	3001077	3001077	3001077	3000275	3001078	3001078	3001078	3001078	3001558

Standard variants

Thread • Keyway • Stroke limitation

4 threads at the front to fix the housing C, D

Instead of longitudinal holes and cross holes the block cylinders can be provided with 4 interior threads, alternatively at the rod side C or at the bottom side D.

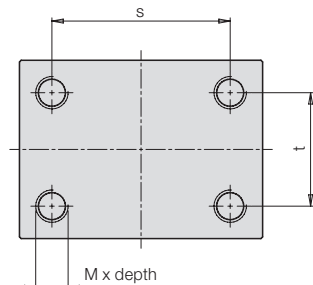

Rod side: 15XXXXXC

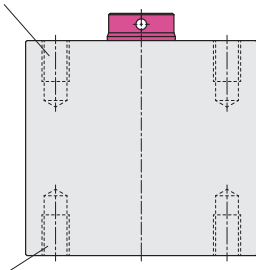

Bottom side: 15XXXXXD

Keyway to support the housing E, F, Q

The block cylinders without longitudinal holes or interior thread can be provided with a keyway for a key.

For pipe thread connection the position of the connecting threads have to be determined in advance (identification code E or F). For manifold-mounting connection (K or L) the identification code is Q.

Pipe thread connection at the right: 15XXXXXE

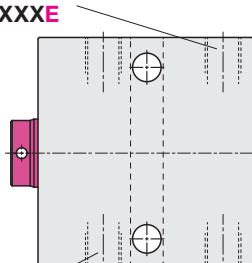

Pipe thread connection at the left: 15XXXXXF

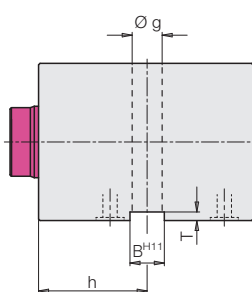

Manifold-mounting connection: 15XXXXXQ

Stroke limitation by distance bushing H

The extending piston stroke of block cylinders can be limited by installing a distance bushing.

The minimum stroke should not be less than 1 mm. The maximum stroke possible based on the standard stroke is indicated in the below table.

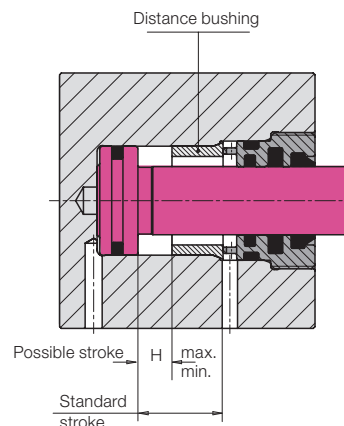

Example: Possible stroke

Block cylinder 1545 165

Standard stroke 50 mm

As per table:

Hmin = 1 mm

Hmax = 50 - 3 = 47 mm

Possible combinations of standard variants see page 6.

Basic version	Dimensions								
	4 threads C, D			keyway E, F, Q				stroke limitation H	
Part no. (Seite 2 bis 4)	M x depth	s	t	B ^{H11}	T	Ø g	h	Hmin.	Hmax.
1541XXXX	M 6 x 9	40	22	8	2	6,5	30	1	standard stroke - 3
1543XXXX	M 8 x 12	50	30	10	2	8,5	33	1	standard stroke - 3
1544XXXX	M 10 x 15	55	35	12	3	10,5	38	1	standard stroke - 3
1545XXXX	M 10 x 15	63	40	12	3	10,5	40	1	standard stroke - 3
1546XXXX	M 12 x 18	76	45	15	5	13	44	1	standard stroke - 4
1547XXXX	M 16 x 24	95	65	20	5	17	50	1	standard stroke - 4
1548XXXX	M 20 x 30	120	80	24	7	21	60	1	standard stroke - 6
1549XXXX	M 24 x 36	158	108	28	7	25	64	1	standard stroke - 6
1550XXXX	M 30 x 45	180	130	35	7	32	82	2	standard stroke - 8
1551XXXX	M 36 x 54	230	160	42	9	39	92	2	standard stroke - 8
1552XXXX	M 48 x 75	300	220	55	9	52	112	2	standard stroke - 8

General tolerances according to DIN ISO 2768-mH

All dimensions in mm

Examples for ordering:

4 threads

Block cylinder 1547 105 (pipe thread connection) with 4 threads M16 at the bottom side

Part no. 1547 105D

Block cylinder 1547 210 (pipe thread connection) with 4 threads M16 at the rod side

Part no. 1547 210C

Block cylinder 1547 105B (manifold-mounting connection) with 4 threads M16 at the bottom side

Part no. 1547 105BD

Keyway

Block cylinder 1547 100 (pipe thread connection) with keyway and connecting thread at the left side

Part no. 1547 100F

Block cylinder 1547 210 (pipe thread connection) with keyway and connecting thread at the right side

Part no. 1547 210E

Block cylinder 1547 100K (manifold-mounting connection) with keyway

Part no. 1547 100KQ

Stroke limitation

Block cylinder 1547 100 (pipe thread connection) with stroke limitation to 15 mm

Part no. 1547 100H15

Block cylinder 1547 210 (pipe thread connection) with stroke limitation to 125 mm

Part no. 1547 210H125

Block cylinder 1547 100K (manifold-mounting connection) with keyway and stroke limitation to 15 mm

Part no. 1547 100KQH15

Code for part numbers

Code for part numbers of the basic versions*

(page 2 to 4)

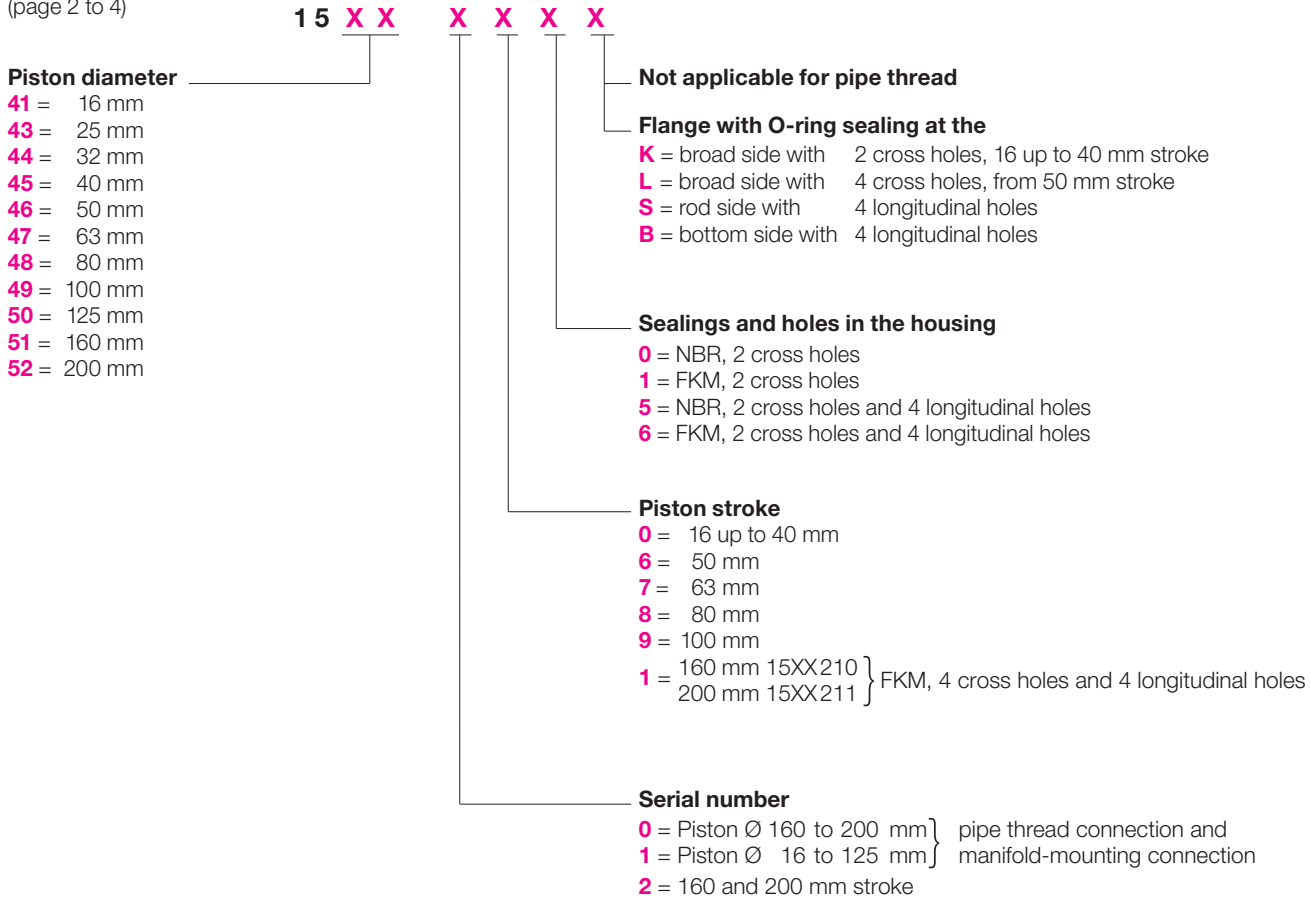

*) Important notes

The code for part numbers allows the **determination of technical data of a known part number**.
The code for part numbers is not suitable for the selection of any variant. Only the versions as per the charts on page 2 or 4 are available as standard elements.
Special variants are available on request.

Code for part numbers of the standard variants and possible combinations

Explanation of the identification codes and order examples see page 5

