



ROEMHELD
HILMA ■ STARK



STARK.balance

Zero point clamping system
Single acting, hydraulic



ROEMHELD
HILMA ■ STARK



STARK INNOVATIVE PROFICIENT INDIVIDUAL RELIABLE

The high-tech company STARK Spannsysteme was established in 1977 in Rankweil, Austria. It manufactures zero point clamping systems and vices of the highest quality and precision for international clients in the automotive, aviation and medical industries, for example.

STARK Spannsysteme products are a byword for minimal set-up times, faster production and high flexibility.

HILMA vices can be complemented and combined perfectly with STARK zero point clamping systems.

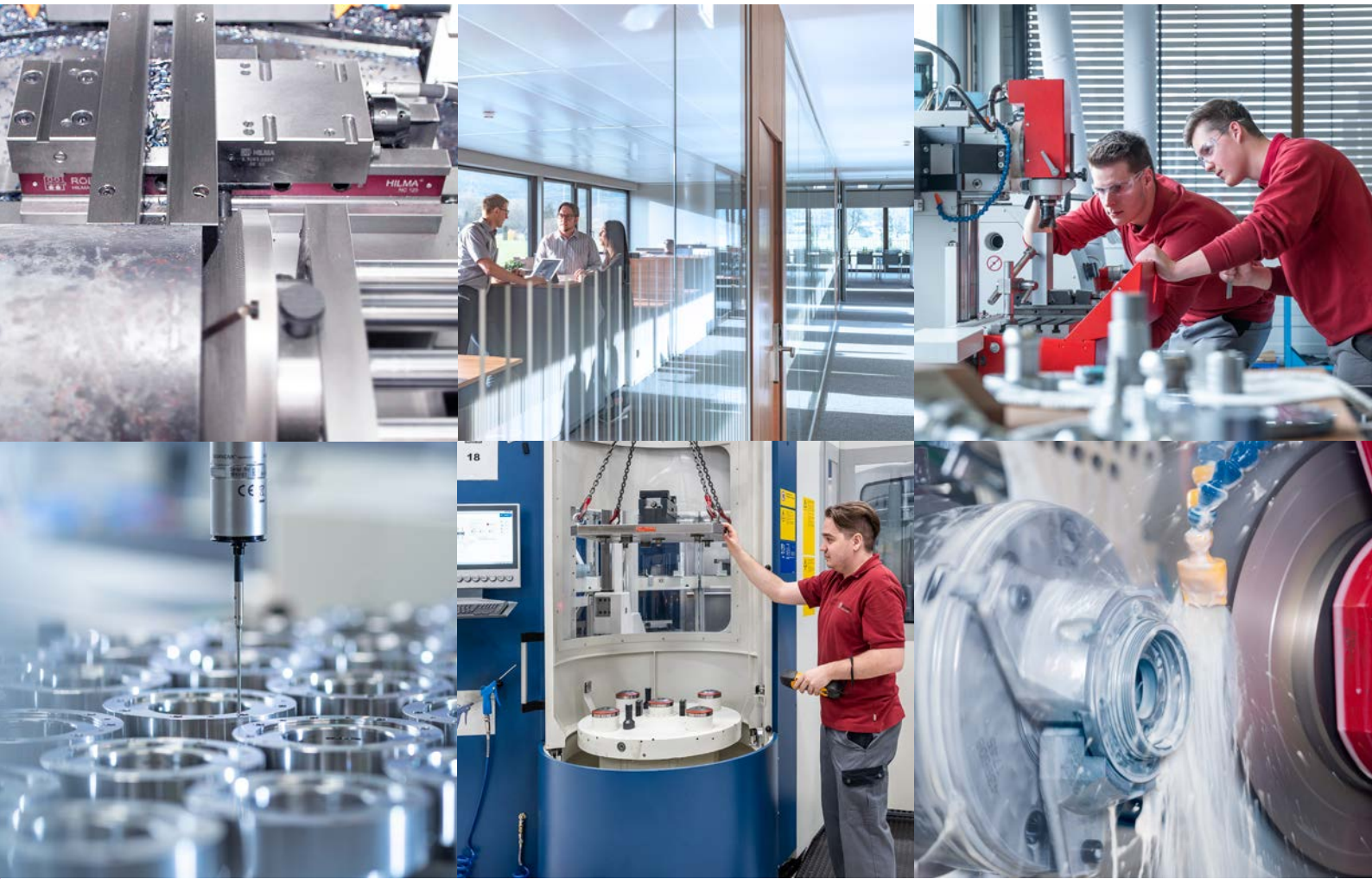

AUTOMOTIVE



AVIATION



MACHINE AND
TOOL
CONSTRUCTION



MEDICINE

FOCUS ON INDUSTRIES AND MAR- KETS.

Every customer has specific requirements. Our established and extensive industry expertise allows us to offer you the best solutions, services and products for sustainable and efficient use in your market.

STARK.balance

Equalising:

equalisation in the element up to $\pm 0.75\text{mm}$

Monitored:

all functions can be queried

Direct:

designed for direct workpiece clamping

Lifting capability:

STARK.balance lifts pallet when released

optimal:

best suited for large devices



STARK.connect



STARK.basic



STARK.hydratec



STARK.airtec

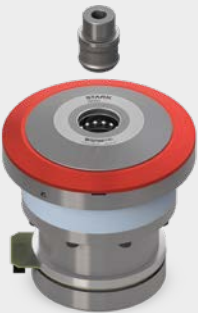

STARK.etc



STARK.sweeper



STARK.easyclick



STARK.metec



STARK.classic



STARK.plaintec

STARK Spannsysteme

More productivity through:

- maximum flexibility in production
- highest process reliability
- reduced manufacturing costs due to set-up time optimisation



STARK.balance Table of Contents

INFORMATION

Functions & benefits	6 - 9
Technical data	10
Tilting moment calculation example	11
STARK.balance function	12
Combination options & tolerance range	14
Queries	16
Optical clamping control	16
Third-hand function (DH)	17
Blow-off & cleaning functional principle	21
Direct clamping	23
Active retraction	25
STARK.balance surface-mounted element functionality	33
Retractable nipple selection & support surface design	35
Retractable nipple fastening versions	39

ELEMENTS

STARK.balance.2 - Standard

STARK.balance.2 D135, installation - NP	18
STARK.balance.2 D135, installation - NP DH	18
STARK.balance.2 D135, installation - AG	18
STARK.balance.2 D135, installation - AG DH	18
STARK.balance.2 D135, installation - OZ	19
STARK.balance.2 D135, installation - OZ DH	19

STARK.balance.2 - Twister

STARK.balance.2 D139, installation - NP	20
STARK.balance.2 D139, installation - NP DH	20
STARK.balance.2 D139, installation - AG	20
STARK.balance.2 D139, installation - AG DH	20
STARK.balance.2 D139, installation - OZ	21
STARK.balance.2 D139, installation - OZ DH	21

STARK.balance.2 - Direct clamping

STARK.balance.2 D135, installation - NP	22
STARK.balance.2 D135, installation - NP DH	22
STARK.balance.2 D135, installation - AG	22
STARK.balance.2 D135, installation - AG DH	22
STARK.balance.2 D135, installation - OZ	23
STARK.balance.2 D135, installation - OZ DH	23

STARK.balance.3 - Standard

STARK.balance.3 D190, installation - NP DH	24
STARK.balance.3 D190, installation - AG DH	24
STARK.balance.3 D190, installation - OZ DH	25

STARK.balance.3 - Twister

STARK.balance.3 D190, installation - NP DH	26
STARK.balance.3 D190, installation - AG DH	26
STARK.balance.3 D190, installation - OZ DH	27

STARK.balance.3 - Direct clamping

STARK.balance.3 D190, installation - NP DH	28
STARK.balance.3 D190, installation - AG DH	28
STARK.balance.3 D190, installation - OZ DH	29
Application example – turning machines	30
Application example – milling machines	31

SURFACE-MOUNTED ELEMENT

STARK.balance.2 D135, surface-mounted element	32
STARK.balance.3 D190, surface-mounted element	32
Design – surface-mounted element	33
STARK.spheric, surface-mounted element	33

RETRACTABLE NIPPLE

Retractable nipple STARK.classic.2 - NP	34
Retractable nipple STARK.balance.2 - NP	34
Retractable nipple STARK.balance.2 - NP, M10	35
Retractable nipple STARK.balance.2 - NP, M12	35
Retractable nipple STARK.balance.2 - NP, M16	35
Retractable nipple STARK.balance.2 - NP, M20	35
Retractable nipple STARK.balance.2 - NP, M24	35
Retractable nipple STARK.classic.3 - NP	36
Retractable nipple STARK.balance.3 - NP	36
Retractable nipple STARK.balance.3 - NP, M16	37
Retractable nipple STARK.balance.3 - NP, M20	37
Retractable nipple STARK.balance.3 - NP, M24	37
Retractable nipple STARK.balance.3 - NP, M30	37
Retractable nipple STARK.balance.3 - NP, M36	37

Nipple fastening

Nipple fastening D	38
Nipple fastening E, E1	38
Key for nipple fastening	39

ACCESSORIES

Spacer with O-ring	40
Support disc STARK.balance.2	40
Support disc STARK.balance.3	40
Screw cover	41
Pressure booster RECORD & COMFORT	42
Hydraulic hose	43
Pedal controllers	43
Air-hydraulic clamping pump	44
Specification dimension tester	44
Mechanical insertion force tester	45
List of order numbers	46

Functions and benefits

The STARK.balance fast closing clamp is a hydraulic single-acting zero point clamping system. A piston is held in the clamping position by springs. The clamping mechanism can be moved in the X and Y axis with little force.

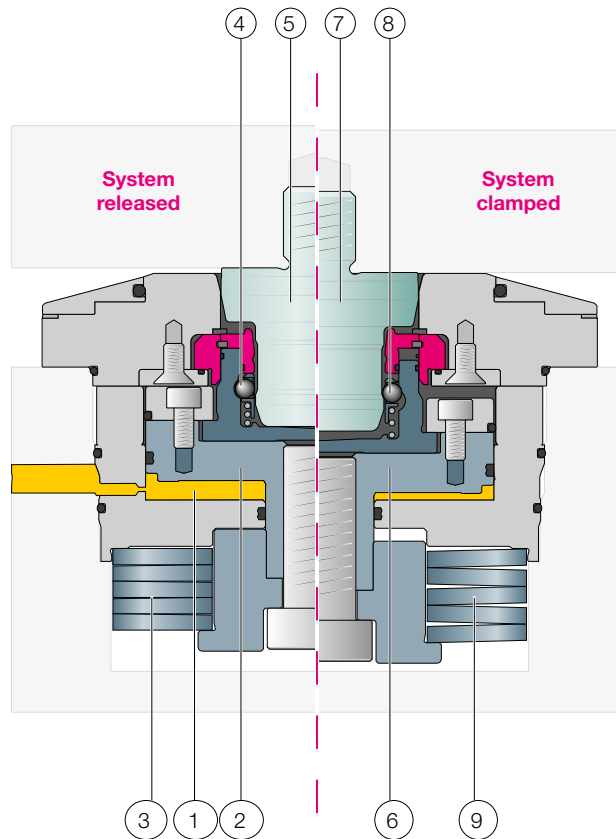

Release hydraulically:

- The piston (2) is subjected to the hydraulic pressure (1) and moves upwards. The spring assembly (3) is compressed.
- The balls in the ball retainer (4) move outwards to the parking position.
- The retractable nipple (5) moves into the fast closing clamp until it rests against the piston crown.
- The clamping mechanism can equalise for position deviations from the retractable nipple to the element with little force. For the equaliser element in one axis and for the element without centring in the X and Y axis ($\pm 0.75\text{mm}$).
- The retractable nipple (5) is pre-positioned.

Clamp mechanically:

- The hydraulics are released. The hydraulic pressure drops to 0 bar.
- The spring pre-tensioning force is initiated via the piston (6), the piston moves down and the ball grips the retractable nipple. The fit is joined and the retractable nipple (7) is positioned with high precision.
- The zero point element positions in both axes and the equaliser element ensures a completely defined system by positioning in one axis.
- The balls (8) lie form-fitted between the piston and the retractable nipple in the contour provided.
- The force of the springs (9) now acts directly and permanently on the retractable nipple and pulls it down into the system.

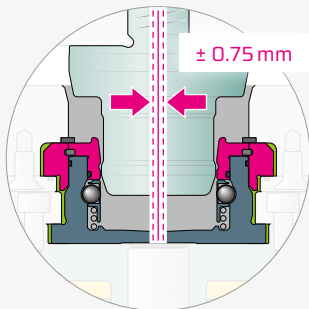

BALANCE FUNCTION

- Compared to a classic zero point clamping system, the STARK.balance fast closing clamp offers a greater equalisation of ± 0.75 mm.
- Specially developed to meet the special requirements of direct clamping and large pallets.

► more on page 12

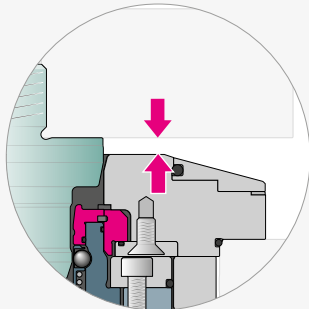

PRE-TENSIONED FORCE AND ACTIVE INSERTION

- Maximum catch range 4.5 mm
- The spring pre-tensioning force is initiated via the piston which moves down. The fit is joined and the retractable nipple is positioned with high precision.
- Media ducts are coupled by the active insertion or decoupled by the lifting.

► more on page 25



QUERIES

- Safety queries with pneumatic clamping and release control are possible as standard. The access lines to the clamping elements are supplied pneumatically via deep-hole bores.
- Clamping control, release control and seat check
- Third-hand function position query

► more on page 16

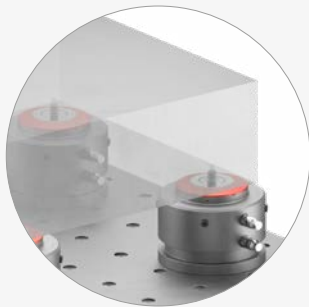

DIRECT CLAMPING

- Thanks to an integrated equaliser function in the STARK.balance fast closing clamp, the workpiece can be clamped directly in the thread without any additional effort.
- Existing threads on the workpiece can be used. A fit is not required.

► more on page 23

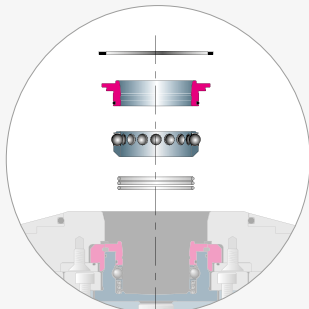

EASE OF SERVICE

- In machining production, contamination of the clamping system is unavoidable in the long term. Therefore, an easy cleaning option is very important.
- For the STARK.balance fast closing clamp, the retaining ring, ball retainer and spring of can be easily removed, cleaned and reinserted after removing the locking ring. This enables easy maintenance and the lowest possible downtimes.
- Easy to exchange due to highly accurate tolerances – no need for set-up or tuning.

Functions and benefits

The STARK.balance.2 and STARK.balance.3 zero point clamping system is available in Standard, Twister and Direct Clamping versions. The STARK.balance.2 elements are available with and without third-hand function (DH), whereas the STARK.balance.3 elements are always designed with DH. The following list shows the different versions with their functions and query options:



Functions and benefits	Standard	Standard THF	Twister	Twister DH	Direct clamping	Direct clamping DH
Balance function – equalisation ±0.75 mm		✓		✓		✓
Pre-tensioned force and active insertion		✓		✓		✓
Query: Clamp control		✓		✓		✓
Query: Release control		✓		✓		✓
Query: Seat check		✓		✓		✓
Query: Position DH	-	✓	-	✓	-	✓
Disc shape for direct clamping		-		-		✓
Ease of service		✓		✓		✓
Wear-resistant insertion and pre-centring		✓		✓		✓
Third-hand function (DH)	-	✓	-	✓	-	✓
Blow-out & blow-off		-		✓		-
Lifting from fit*		✓		✓		✓

- ✓ Standard function
- ✓ Function can be used as an option

* If no lifting is desired for process reasons, shortened nipples can be used.

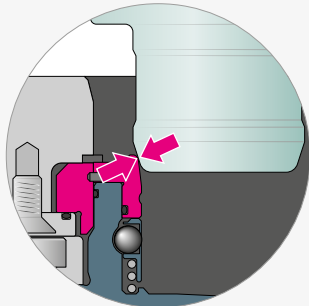

WEAR-RESISTANT INSERTION AND PRE-CENTRING

- Due to the special retractable nipple contour, no damage occurs to the fitting diameter when inserting into the STARK.balance fast closing clamp.
- High alloy tool steel provides wear resistance.

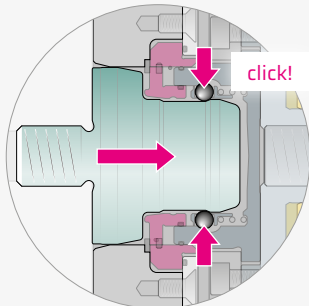

THIRD-HAND FUNCTION (DH)

- The third hand function (DH) engages the workpiece or pallet in the zero point clamping system. Once the pallet or workpiece is engaged on all sides, it is secured against falling out and the clamping process can be completed easily and safely.

▶ more on page 17

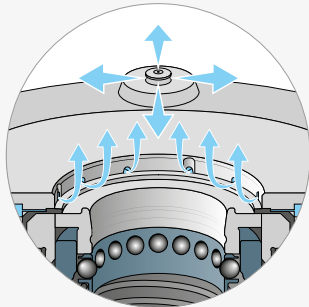

BLOW-OUT & CLEANING

- Intelligent blow-out and blow-off technology for cleaning the support islands and the fitting bore. The blow-off takes place directly at the support surfaces and at the fitting diameter. To clean the support islands, air flows upward and mushroom-shaped downward via retractable nozzles.

▶ more on page 21

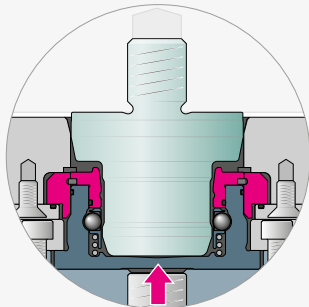

LIFTING FROM FIT

- When releasing, the retractable nipple is lifted out of the fit in a controlled manner and the operator sees that the system is released. This makes handling safe and extremely simple. Controlled movement in and out of the fit minimises wear on the fit.

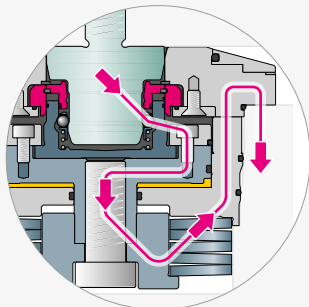

OPTIMAL FORCE PROGRESSION

- High positioning accuracy due to optimum force flow – no bending or lifting.
- Systems with active insertion ensure stable force transmission – the force is transmitted from the workpiece via the retractable nipple into the element and via the element housing further into the machine table.
- Spring force permanently pulls the retractable nipples into the system in a form-fit and highly precise manner – this has a vibration-damping effect and increases the quality of the surface to be processed as well as the service life of the tools.



Technical data



		STARK.balance.2	STARK.balance.3
Maintenance interval	Cycles	40,000	40,000
Insertion force ¹	[N]	20,000	30,000
Retention force ²	[N]	38,000	55,000
Min. release pressure	[bar]	60	38
Lifting force at 60 bar / 80 bar	[N]	0 / 15,000	-
Lifting force at 38 bar / 80 bar	[N]	-	0 / 31,500
Lifting	[mm]	1.2	2
Insertion	[mm]	1.2	4.5
Max. pressure	[bar]	80	
Oil volume	[cm ³]	22	132.5
Min. permitted clamping & release time	[s]	2	
Radial pre-positioning ³	[mm]	±2.5	±2.5
Axial pre-positioning ⁴	[mm]	-0.3	
Repeat accuracy ⁵	[mm]	< 0.005	
System accuracy ⁶	[mm]	< 0.01	

- ¹ Insertion force: The insertion force (pre-tensioning force of the spring assembly) is the load up to which the zero point is guaranteed. The specified insertion force must not be exceeded.
- ² Retention force: This is the maximum overload at which the retractable nipple is still held but the zero point has already been left.
- ³ Radial pre-positioning: The loading device must be compliant for automated loading.
- ⁴ Axial pre-positioning: Retractable nipple is in contact with the piston crown before the clamping process. A gap of max. 0.3 mm is permissible.
- ⁵ Repeat accuracy: This usually indicates the accuracy that refers to the change of the same pallet position-oriented on the same interface.
- ⁶ System accuracy: This refers to the accuracy resulting from changing several pallets, e.g. on different machines.

Tilting moment calculation example

INFO

Tilting moment calculation example

Example:

Fast closing clamp plate 4 STARK.balance.2 with spacing 400 x 400 and max. feed force of 10 kN with distance of 1000 mm.

Question:

Due to the predominance of roughing work, the system is to be checked for a double safety factor. Is the insertion force, the number of fast closing clamps and the spacing selected adequate?

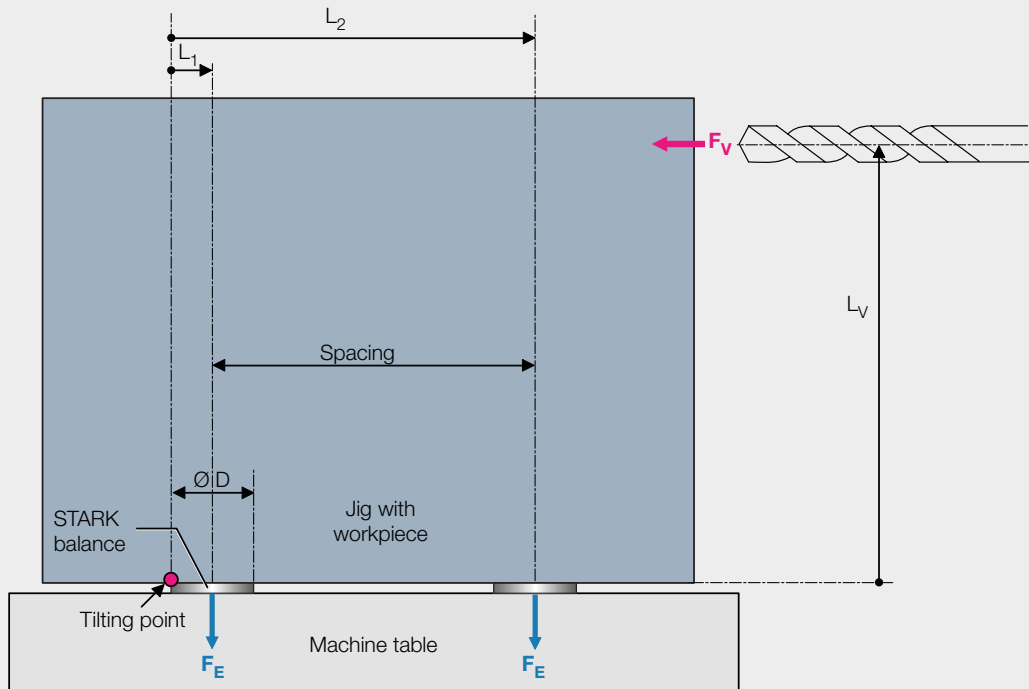

Solution:

$M_E > 2 \times M_V$?

$M_V = F_V \times L_V = 10,000 \text{ N} \times 1.0 \text{ m}$

$M_V = 10,000 \text{ Nm}$

$M_E = 2 \times (F_E \times L_1) + 2 \times (F_E \times L_2)$

$M_E = 2 \times F_E \times (L_1 + L_2)$

$L_1 = \text{Ø} D / 2$

$L_2 = \text{Ø} D / 2 + \text{Spacing}$

$L_1 + L_2 = \text{Ø} D + \text{Spacing}$

$L_1 + L_2 = 0.135 \text{ m} + 0.40 \text{ m} = 0.535 \text{ m}$

$M_E = 2 \times F_E \times (L_1 + L_2) = 2 \times 20,000 \text{ N} \times 0.535 \text{ m}$

$M_E = 21,400 \text{ Nm}$

$M_E / M_V > 2$?

$M_E / M_V = 21,400 \text{ Nm} / 10,000 \text{ N}$

$M_E / M_V = 2.14 > 2$

With this design there is a safety factor of around two.

(Enter all variables in SI units (metres, newtons))

M_V : Moment from feed force

M_E : Moment from insertion force

F_V : Feed force (10,000 N)

F_E : Insertion force (20,000 N)

Spacing = 400 mm = 0.40 m

Ø D (bearing ring) : 135 mm = 0.135 m

L_V : 1,000 mm = 1.00 m

STARK.balance function

The STARK.balance fast closing clamp offers a very large equalisation of ± 0.75 mm and has been specially developed to meet the special requirements for direct clamping and large pallets.

Functional principle

- During the clamping process, the retractable nipple moves into the fast closing clamp until it rests against the piston crown.
- The clamping mechanism (1) & (2) can equalise for position deviations from the retractable nipple to the element with little force. For the equaliser element in one axis and for the element without centring in the X and Y axis (± 0.75 mm).

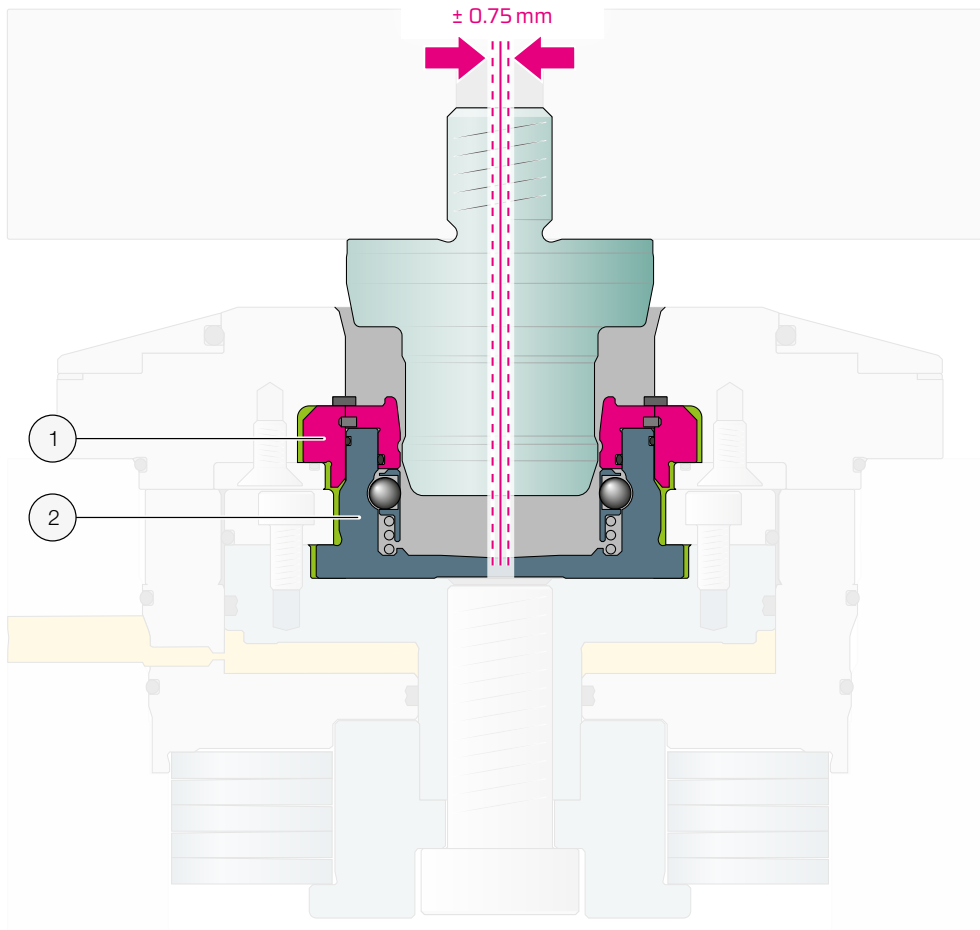

INFO

Equalisation via fast closing clamp

Area of application

- Different materials between pallet and plate
- Pallets with the same retractable nipple
- For a large number of pallets
- Workpiece direct clamping
- Tolerance range ± 0.75 mm

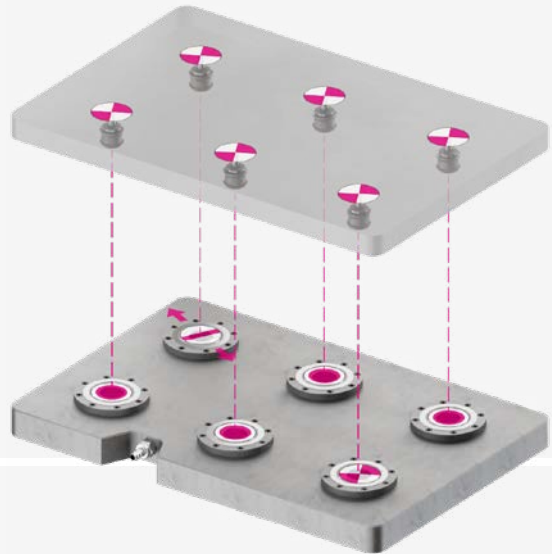

STARK.balance - Function
Zero point accuracy with equaliser

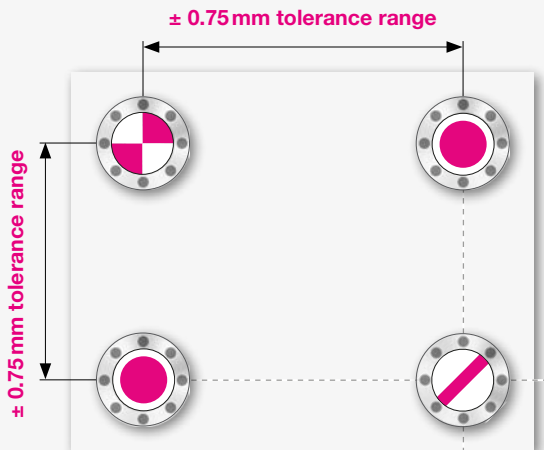

■ Low production costs

For large spacings, the advantage of a large equalisation can lead to much cheaper manufacture and thus significant cost savings. There are no processing steps, which also reduces the cycle time for the manufacturing of fast closing plates and pallets.

■ Thermal expansion

Temperature changes, e.g. night 17 °C / day 32 °C, require special precautions to prevent redundant dimensioning (e.g. in the case of aluminium, this change in temperature modifies spacing from 1000 mm to 1000.36 mm).

■ Manufacturing tolerances

Due to the large equalisation, it is sufficient to prepare the position of the elements and retractable nipples with generous tolerances. The entire system is always zero point accurate.

You determine the zero point

Zero point and axis alignment are retained and are always known. A total of up to ± 0.75 mm can be compensated.

- with zero point (NP)
- with equaliser (AG)
- without centring (OZ)

Combination options & tolerance range¹³

Depending on the requirement, there are many possibilities to equalise tolerances with different materials and device sizes.



STARK.balance.2		Retractable nipple			Spacer	Support disc
		STARK.classic.2 S804-470	STARK.balance.2 S804-474	STARK.balance.2 S801-22x, S801-230	S801-280	S804-281
Standard NP Standard NP DH	S801-201 S801-204	✓	✓			
Standard AG Standard AG DH	S801-202 S801-205	✓ ±0.75 mm ¹	✓ ±0.75 mm ¹	-	-	✓
Standard OZ Standard OZ DH	S801-203 S801-206	✓ ±0.75 mm ²	✓ ±0.75 mm ²			
Direct clamping NP Direct clamping NP DH	S801-207 S801-210			✓		
Direct clamping AG Direct clamping AG DH	S801-208 S801-211	-	-	✓ ±0.75 mm ¹	-	-
Direct clamping OZ Direct clamping OZ DH	S801-209 S801-212			✓ ±0.75 mm ²		
Twister NP Twister NP DH	S801-213 S801-216		✓			
Twister AG Twister AG DH	S801-214 S801-217	-	✓ ±0.75 mm ¹	-	✓	✓
Twister OZ Twister OZ DH	S801-215 S801-218		✓ ±0.75 mm ²			

- ✓ Recommended combination
- ✓ Possible combination
- ¹ Equaliser of theoretical centre in equalisation direction
- ² Equaliser of radial theoretical centre in all directions
- DH Third-hand function

Values correspond to the radial tolerance for the position of element and retractable nipple including expected temperature variation



STARK.balance.3		Retractable nipple			Spacer	Support disc
		STARK.classic.3 S804-290	STARK.balance.3 S04156	STARK.balance.3 S801-330, S801-32x	S801-260	S03643
Standard NP DH	S801-301	✓	✓			
Standard AG DH	S801-302	✓ ±0.75mm ¹	✓ ±0.75mm ¹	—	—	✓
Standard OZ DH	S801-303	✓ ±0.75mm ²	✓ ±0.75mm ²			
Direct clamping NP DH	S801-304			✓		
Direct clamping AG DH	S801-305	—	—	✓ ±0.75mm ¹	—	—
Direct clamping OZ DH	S801-306			✓ ±0.75mm ²		
Twister NP DH	S801-307		✓			
Twister AG DH	S801-308	—	✓ ±0.75mm ¹	—	✓	✓
Twister OZ DH	S801-309		✓ ±0.75mm ²			

- ✓ Recommended combination
- ✓ Possible combination
- ¹ Equaliser of theoretical centre in equalisation direction
- ² Equaliser of radial theoretical centre in all directions
- DH Third-hand function

Values correspond to the radial tolerance for the position of element and retractable nipple including expected temperature variation

Queries

In the STARK.balance zero point clamping system, safety queries with pneumatic clamping and release control are possible as standard. The access lines to the clamping elements are supplied pneumatically via deep-hole bores. This involves a dynamic pressure query. The seat check also works with dynamic pressure, but only serves as a precision check. Optionally, all elements are available with a third-hand function (DH). In addition to the query options integrated in the machine control system, the optical clamping control provides an option for clamping control independent of the machine.

System internal queries

Dynamic pressure is generated by the piston position

- **Release control**
Perfect for automation and heavy components
- **Clamping control**
Safety query
- **Third-hand function (DH)**
Status query for safe handling

The valve position corresponds to the respective positive message of the query.
Released control in the released position
Clamped control in the clamped position
DH control in the DH position

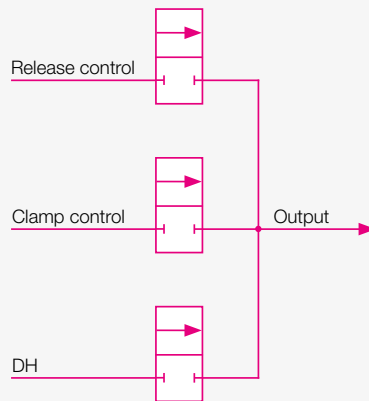

Query outside the element

Dynamic pressure is generated by the workpiece system

- **Seat check**
Precision check

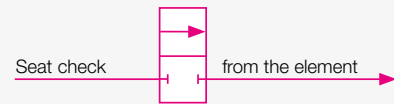

INFO

Optical clamping control

Is the zero point clamping system securely clamped?

In many applications, e.g. when turning, clamp control is mandatory. The visual clamp control shows the position of the piston after activation of the clamp control in the fast closing clamp and provides absolutely reliable information via a traffic light signal.

Simple operation and easy retrofitting are key advantages with this safety component.

The optical clamping control can be integrated into the fast closing plate.



The green display shows that clamping is correct.



The display changes to red when releasing until positive clamp control occurs again.

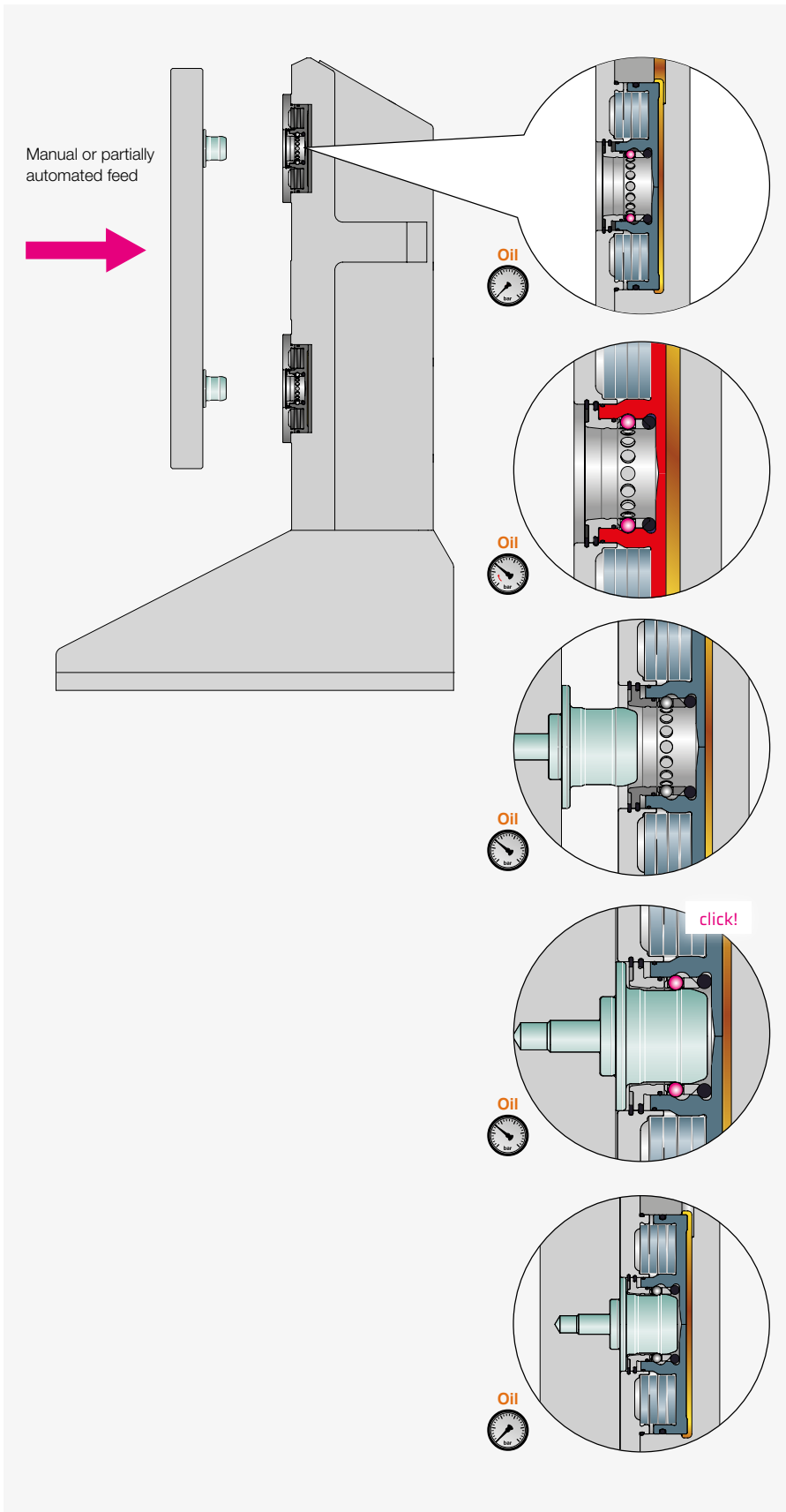

THIRD-HAND FUNCTION

- Schematic diagram for all STARK elements with third-hand function (DH)

HOLDING FUNCTION

- The fast closing clamp is applied with the holding pressure and is ready for the secure engagement of the pallet.

FEEDING

- The pallet is fed by hand or by crane.

ENGAGING

- The retractable nipples are retracted, engaged and then mechanically secured. You can release the pallet.

POSITIONING AND CLAMPING

- The fast closing clamp is depressurised. The pallet is now positioned, inserted and securely clamped via the cup springs.

STANDARD BALANCE.2 ELEMENTS

STARK.balance.2 D135, installation - NP



Fast closing clamp made of high-quality tool steel

- Installation module \varnothing 135 mm, standard
- Element with zero point
- Hydraulic single acting
- with clamping, release and seat check
- Third-hand function (DH), optional

Properties

- Retention force: 38,000 N
- Insertion force: 38,000 N
- Pressure: min. 60 bar, max. 80 bar
- Weight: 5.2 kg
- Installation according to data sheet D139
- Operating Manual WM-020-369-xx-xx

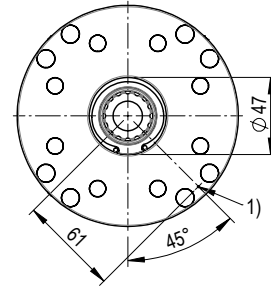
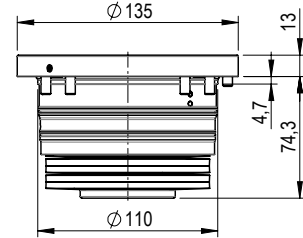

Z_S801-201_01

- 1) Seat check
- Cylinder screw with hexagon socket M6 x 16mm S931-138, enclosed separately
 - Screw cover M6 S999-408, enclosed separately
 - O-ring \varnothing 4.0 x 1.5mm S933-200, enclosed separately
 - Shaft screw S931-653 M6 x 12, enclosed separately

Order number	Article designation	Function
S801-201	SE Z2 H 200 D135 ST NP	Standard
S801-204	SE Z2 H 200 D135 ST NP DH	with third-hand function (DH)

► Third-hand function (DH) – see info page 17

STARK.balance.2 D135, installation - AG



Fast closing clamp made of high-quality tool steel

- Installation module \varnothing 135 mm, standard
- Element with equaliser (floating area in one axis ± 0.75 mm)
- Hydraulic single acting
- with clamping, release and seat check
- Third-hand function (DH), optional

Properties

- Retention force: 38,000 N
- Insertion force: 38,000 N
- Pressure: min. 60 bar, max. 80 bar
- Weight: 5.2 kg
- Installation according to data sheet D139
- Operating Manual WM-020-369-xx-xx

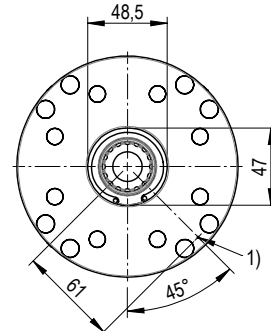
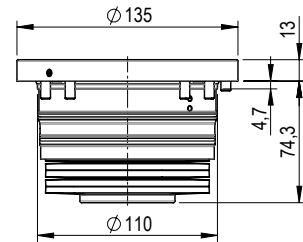

Z_S801-202_01

- 1) Seat check
- Cylinder screw with hexagon socket M6 x 16mm S931-138, enclosed separately
 - Screw cover M6 S999-408, enclosed separately
 - O-ring \varnothing 4.0 x 1.5mm S933-200, enclosed separately
 - Shaft screw S931-653 M6 x 12, enclosed separately

Order number	Article designation	Function
S801-202	SE Z2 H 200 D135 ST AG	Standard
S801-205	SE Z2 H 200 D135 ST AG DH	with third-hand function (DH)

► Third-hand function (DH) – see info page 17

STARK.balance.2 D135, installation - OZ



Fast closing clamp made of high-quality tool steel

- Installation module \varnothing 135 mm, standard
- Element without centring (circumferential floating area ± 0.75 mm)
- Hydraulic single acting
- with clamping, release and seat check
- Third-hand function (DH), optional

Properties

- Retention force: 38,000 N
- Insertion force: 38,000 N
- Pressure: min. 60 bar, max. 80 bar
- Weight: 5.2 kg
- Installation according to data sheet D139
- Operating Manual WM-020-369-xx-xx

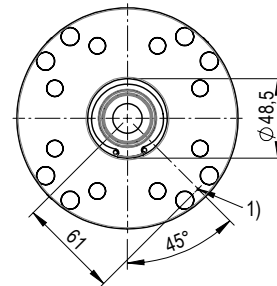
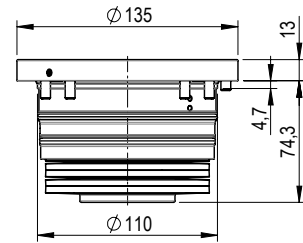

Z_S801-203_01

- 1) Seat check
 - Cylinder screw with hexagon socket M6 x 16mm S931-138, enclosed separately
 - Screw cover M6 S999-408, enclosed separately
 - O-ring \varnothing 4.0 x 1.5mm S933-200, enclosed separately
 - Shaft screw S931-653 M6 x 12, enclosed separately

Order number	Article designation	Function
S801-203	SE Z2 H 200 D135 ST OZ	Standard
S801-206	SE Z2 H 200 D135 ST OZ DH	with third-hand function (DH)

► Third-hand function (DH) – see info page 17

ELEMENT TWISTER BALANCE.2

STARK.balance.2 D139, installation - NP



Fast closing clamp made of high-quality tool steel

- Installation module Ø 139 mm, Twister with blow-out via 4 support islands (Ø 16 mm)
- Element with zero point
- Hydraulic single acting
- with clamping, release and seat check
- Third-hand function (DH), optional

Properties

- Retention force: 38,000 N
- Insertion force: 38,000 N
- Pressure: min. 60 bar, max. 80 bar
- Weight: 5.4 kg
- Installation according to data sheet D139
- Operating Manual WM-020-369-xx-xx

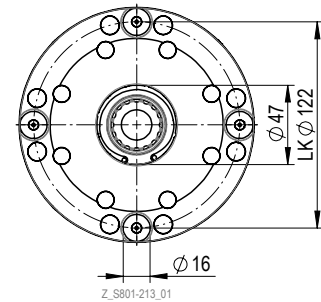
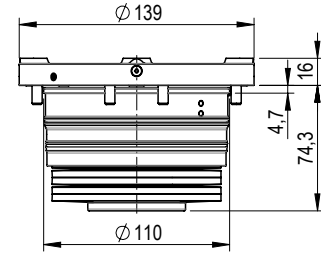

- Cylinder screw with hexagon socket M6 x 16 mm S931-138, enclosed separately
 - Screw cover M6 S999-408, enclosed separately
 - O-ring Ø 7.0 x 1.5 mm S933-043, enclosed separately
 - O-ring Ø 4.0 x 1.5 mm S933-200, enclosed separately
 - Shaft screw S931-653 M6 x 12, enclosed separately

Z_S801-213_01

Order number	Article designation	Function
S801-213	SE Z2 H 200 D139 TW NP	Standard
S801-216	SE Z2 H 200 D139 TW NP DH	with third-hand function (DH)

▶ Third-hand function (DH) – see info page 17

STARK.balance.2 D139, installation - AG



Fast closing clamp made of high-quality tool steel

- Installation module Ø 139 mm, Twister with blow-out via 4 support islands (Ø 16 mm)
- Element with equaliser (floating area in one axis ±0.75 mm)
- Hydraulic single acting
- with clamping, release and seat check
- Third-hand function (DH), optional

Properties

- Retention force: 38,000 N
- Insertion force: 38,000 N
- Pressure: min. 60 bar, max. 80 bar
- Weight: 5.4 kg
- Installation according to data sheet D139
- Operating Manual WM-020-369-xx-xx

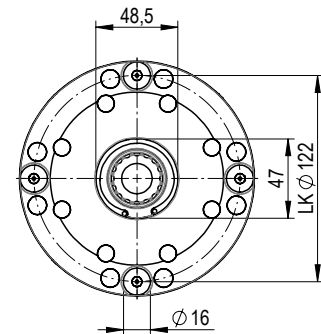
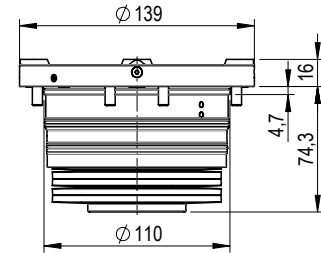

- Cylinder screw with hexagon socket M6 x 16 mm S931-138, enclosed separately
 - Screw cover M6 S999-408, enclosed separately
 - O-ring Ø 7.0 x 1.5 mm S933-043, enclosed separately
 - O-ring Ø 4.0 x 1.5 mm S933-200, enclosed separately
 - Shaft screw S931-653 M6 x 12, enclosed separately

Z_S801-214_01

Order number	Article designation	Function
S801-214	SE Z2 H 200 D139 TW AG	Standard
S801-217	SE Z2 H 200 D139 TW AG DH	with third-hand function (DH)

▶ Third-hand function (DH) – see info page 17

STARK.balance.2 D139, installation - OZ



Fast closing clamp made of high-quality tool steel

- Installation module \varnothing 139 mm, Twister with blow-out via 4 support islands (\varnothing 16 mm)
- Element without centring (circumferential floating area ± 0.75 mm)
- Hydraulic single acting
- with clamping, release and seat check
- Third-hand function (DH), optional

Properties

- Retention force: 38,000 N
- Insertion force: 38,000 N
- Pressure: min. 60 bar, max. 80 bar
- Weight: 5.4 kg
- Installation according to data sheet D139
- Operating Manual WM-020-369-xx-xx

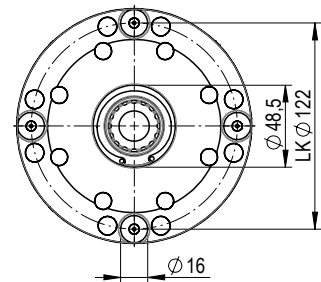
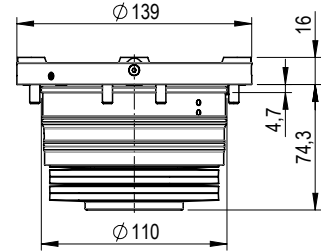

Z_S801-215_01

- Cylinder screw with hexagon socket M6 x 16 mm S831-138, enclosed separately
 - Screw cover M6 S999-408, enclosed separately
 - O-ring \varnothing 7.0 x 1.5 mm S993-043, enclosed separately
 - O-ring \varnothing 4.0 x 1.5 mm S993-200, enclosed separately
 - Shaft screw S831-653 M6 x 12, enclosed separately

Order number	Article designation	Function
S801-215	SE Z2 H 200 D139 TW OZ	Standard
S801-218	SE Z2 H 200 D139 TW OZ DH	with third-hand function (DH)

► Third-hand function (DH) – see info page 17

INFO

Blow-off & cleaning functional principle

Intelligent blow-out and blow-off technology for cleaning the support islands and the fitting bore. The blow-off takes place directly at the support surfaces and at the fitting diameter. To clean the support islands, air flows upward and mushroom-shaped downward via retractable nozzles.

- 1) Island blow-off
- 2) Centre blow-off
- 3) Island blow-off
Nozzle functionality
- 4) Island blow-off
Nozzle retracted
- 5) Island blow-off
Nozzle extended
- 6) Openings for centre blow-off

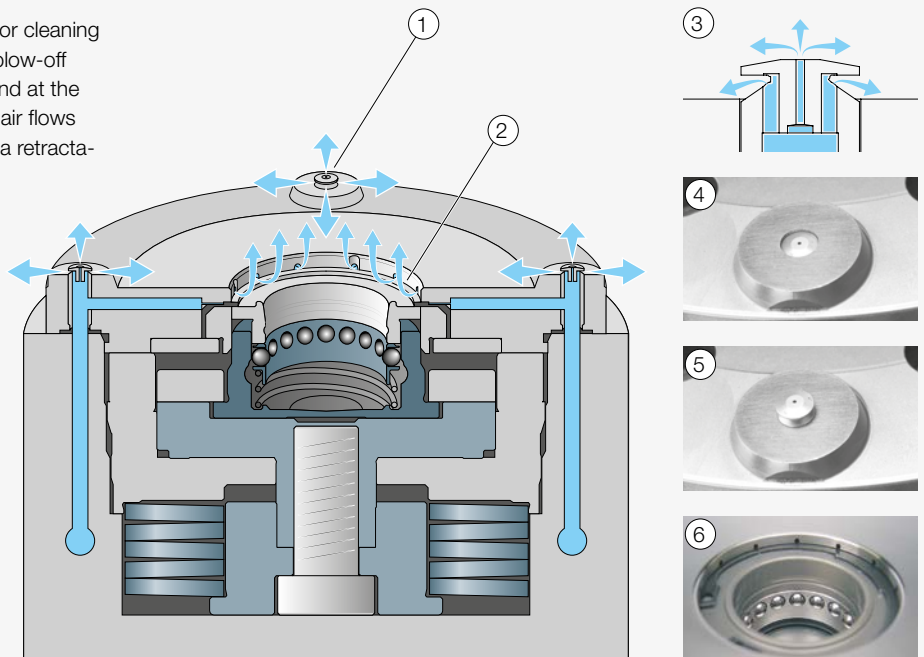

BALANCE.2 DIRECT CLAMPING ELEMENTS

STARK.balance.2 D135, installation - NP



Fast closing clamp made of high-quality tool steel

- Installation module \varnothing 135 mm with raised support ring for direct clamping
- Element with zero point
- Hydraulic single acting
- with clamping, release and seat check
- Third-hand function (DH), optional

Properties

- Retention force: 38,000 N
- Insertion force: 38,000 N
- Pressure: min. 60 bar, max. 80 bar
- Weight: 5.7 kg
- Installation according to data sheet D139
- Operating Manual WM-020-369-xx-xx

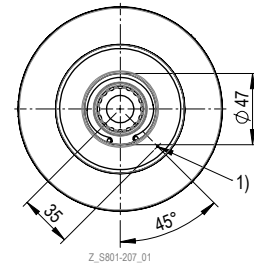
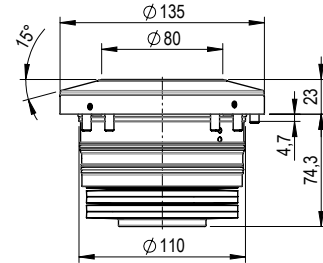

Z_S801-207_01

1) Seat check
- Cylinder screw with hexagon socket M6 x 16 mm S931-138, enclosed separately
- O-ring \varnothing 4.0 x 1.5 mm S933-200, enclosed separately
- Shaft screw S831-653 M6 x 12, enclosed separately

Order number	Article designation	Function
S801-207	SE Z2 H 200 D135 EH NP	Standard
S801-210	SE Z2 H 200 D135 EH NP DH	with third-hand function (DH)

► Third-hand function (DH) – see info page 17

STARK.balance.2 D135, installation - AG



Fast closing clamp made of high-quality tool steel

- Installation module \varnothing 135 mm with raised support ring for direct clamping
- Element with equaliser (floating area in one axis ± 0.75 mm)
- Hydraulic single acting
- with clamping, release and seat check
- Third-hand function (DH), optional

Properties

- Retention force: 38,000 N
- Insertion force: 38,000 N
- Pressure: min. 60 bar, max. 80 bar
- Weight: 5.7 kg
- Installation according to data sheet D139
- Operating Manual WM-020-369-xx-xx

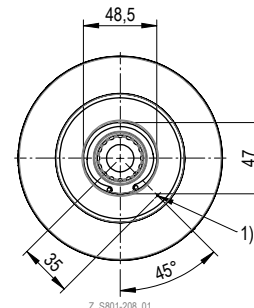
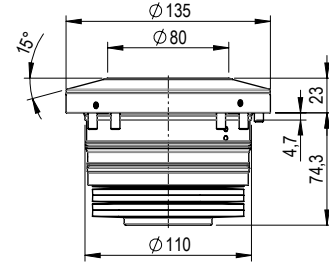

Z_S801-208_01

1) Seat check
- Cylinder screw with hexagon socket M6 x 16 mm S931-138, enclosed separately
- O-ring \varnothing 4.0 x 1.5 mm S933-200, enclosed separately
- Shaft screw S831-653 M6 x 12, enclosed separately

Order number	Article designation	Function
S801-208	SE Z2 H 200 D135 EH AG	Standard
S801-211	SE Z2 H 200 D135 EH AG DH	with third-hand function (DH)

► Third-hand function (DH) – see info page 17

STARK.balance.2 D135, installation - OZ



Fast closing clamp made of high-quality tool steel

- Installation module \varnothing 135 mm with raised support ring for direct clamping
- Element without centring (circumferential floating area ± 0.75 mm)
- Hydraulic single acting
- with clamping, release and seat check
- Third-hand function (DH), optional

Properties

- Retention force: 38,000 N
- Insertion force: 38,000 N
- Pressure: min. 60 bar, max. 80 bar
- Weight: 5.7 kg
- Installation according to data sheet D139
- Operating Manual WM-020-369-xx-xx

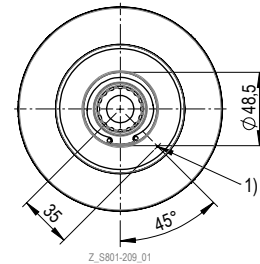
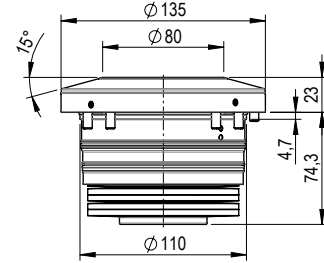

Z_S801-209_01

- 1) Seat check
- Cylinder screw with hexagon socket M6 x 16 mm S831-138, enclosed separately
- O-ring \varnothing 4.0 x 1.5 mm S833-200, enclosed separately
- Shaft screw S831-653 M6 x 12, enclosed separately

Order number	Article designation	Function
S801-209	SE Z2 H 200 D135 EH OZ	Standard
S801-212	SE Z2 H 200 D135 EH OZ DH	with third-hand function (DH)

► Third-hand function (DH) – see info page 17

INFO

Direct clamping

STARK has developed the STARK.balance product families for the special requirements for direct workpiece clamping.

The STARK.balance series has special advantages: Existing threads on the workpiece can be used. A special fit is not required. Thanks to an integrated equaliser function in the clamping element ± 0.75 mm, the workpiece can be clamped directly in the thread without any additional effort.

The retractable nipples are available with different threads. They can be screwed in either manually or automatically.

The system is zero point accurate and therefore the workpiece can be used across several machines or for intermediate measurements.

Example requirements

- Workpiece processing with zero point accuracy across multiple machines
- 5-side accessibility
- Use existing threads on the workpiece
- Zero point oriented flexibility
- Equaliser options for tolerances and temperature variation
- Predestined for cast parts

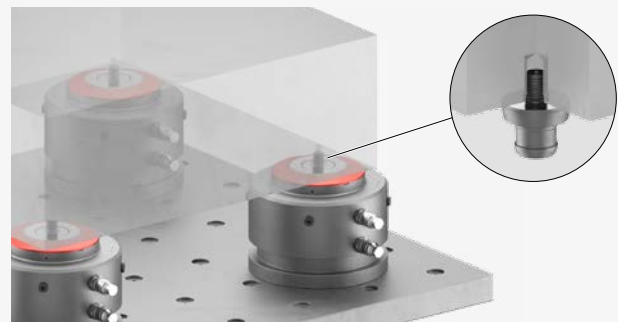

STANDARD BALANCE.3 ELEMENTS

STARK.balance.3 D190, installation - NP



Fast closing clamp made of high-quality tool steel. System is hydraulically single acting.

- Installation module \varnothing 190 mm
- Element with zero point
- Hydraulic single acting
- with support ring
- with clamping, release and seat check
- with third-hand function (DH)

Properties

- Retention force: 38,000 N
- Insertion force: 38,000 N
- Pressure: min. 38 bar, max. 80 bar
- Weight: 16.15 kg
- Installation according to data sheet D183
- Operating Manual WM-020-369-xx-xx

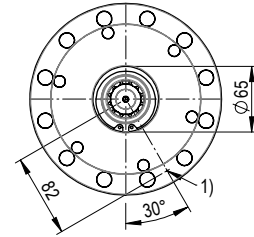
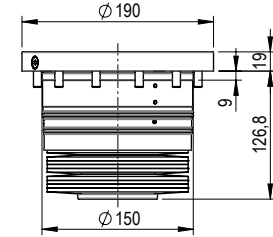

Z_S801-301_00

- 1) Seat check
- Cylinder screws with hexagon socket M8 x 25 mm S931-389, enclosed separately
 - Screw covers M8 055-146-05, enclosed separately
 - O-ring \varnothing 7.0 x 1.5 mm S933-043, enclosed separately
 - Clamping pin \varnothing 6.0 x 12 mm S936-215, enclosed separately

Order number	Article designation	Function
S801-301	SE Z3 H 300 D190 ST NP DH	with third-hand function (DH)

► Third-hand function (DH) – see info page 17

STARK.balance.3 D190, installation - AG



Fast closing clamp made of high-quality tool steel

- Installation module \varnothing 190 mm, standard
- Element with equaliser (floating area in one axis \pm 0.75 mm)
- Hydraulic single acting
- with support ring
- with clamping, release and seat check
- with third-hand function (DH)

Properties

- Retention force: 38,000 N
- Insertion force: 38,000 N
- Pressure: min. 38 bar, max. 80 bar
- Weight: 16.15 kg
- Installation according to data sheet D183
- Operating Manual WM-020-369-xx-xx

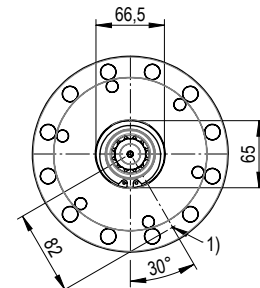
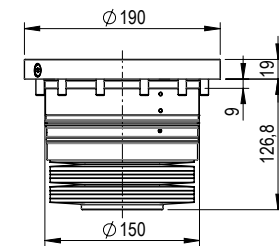

Z_S801-302_00

- 1) Seat check
- Cylinder screws with hexagon socket M8 x 25 mm S931-389, enclosed separately
 - Screw covers M8 055-146-05, enclosed separately
 - O-ring \varnothing 7.0 x 1.5 mm S933-043, enclosed separately
 - Clamping pin \varnothing 6.0 x 12 mm S936-215, enclosed separately

Order number	Article designation	Function
S801-302	SE Z3 H 300 D190 ST AG DH	with third-hand function (DH)

► Third-hand function (DH) – see info page 17

STARK.balance.3 D190, installation - OZ



Fast closing clamp made of high-quality tool steel

- Installation module \varnothing 190 mm, standard
- Element without centring (circumferential floating area ± 0.75 mm)
- Hydraulic single acting
- with support ring
- with clamping, release and seat check
- with third-hand function (DH)

Properties

- Retention force: 38,000 N
- Insertion force: 38,000 N
- Pressure: min. 38 bar, max. 80 bar
- Weight: 16.15 kg
- Installation according to data sheet D183
- Operating Manual WM-020-369-xx-xx

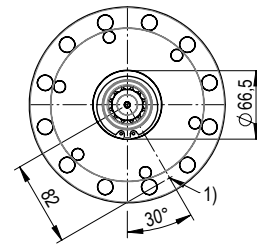
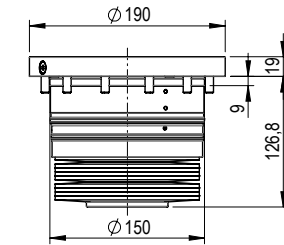

Z_S801-303_00

1) Seat check
 - Cylinder screws with hexagon socket M8 x 25mm S931-389, enclosed separately
 - Screw covers M8 055-146-05, enclosed separately
 - O-ring \varnothing 7.0 x 1.5mm S933-043, enclosed separately
 - Clamping pin \varnothing 6.0 x 12mm S936-215, enclosed separately

Order number	Article designation	Function
S801-303	SE Z3 H 300 D190 ST OZ DH	with third-hand function (DH)

► Third-hand function (DH) – see info page 17

INFO

Active retraction

The larger STARK.balance.3 series has a particularly large insertion of 4.5 mm.

This results in the following advantages:

- Simplified, secure fixing, especially in vertical machining increases work and process reliability
- Faster, precise positioning of large workpieces to optimise set-up time
- Equalisation of unevenness in favour of repeat accuracy
- Combination with Roemheld couplings

Overall, a high insertion leads to more efficient, precise and flexible machining, which contributes to an increase in the overall productivity and quality of the manufacturing processes.

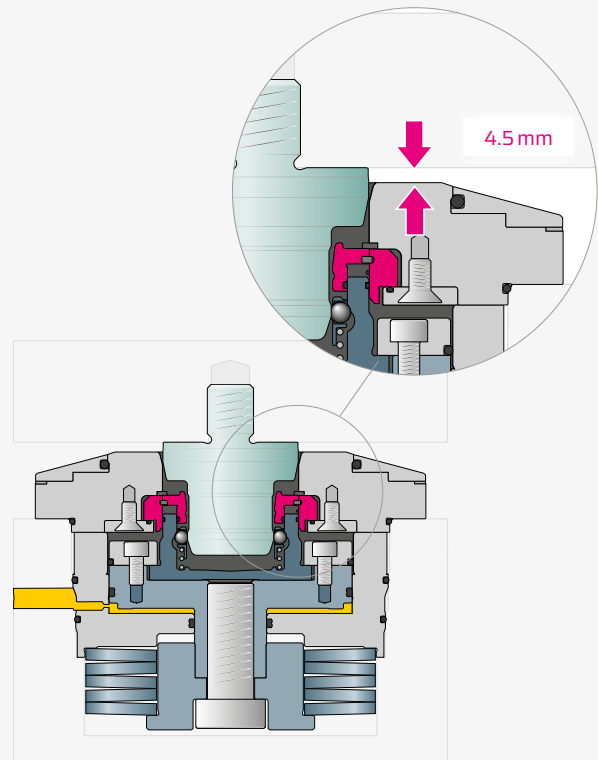

ELEMENT TWISTER BALANCE.3

STARK.balance.3 D190, installation - NP



Fast closing clamp made of high-quality tool steel

- Installation module Ø 190 mm, Twister with blow-out via 4 support islands (Ø 21 mm)
- Element with zero point
- Hydraulic single acting
- with clamping, release and seat check
- with third-hand function (DH)

Properties

- Retention force: 38,000 N
- Insertion force: 38,000 N
- Pressure: min. 38 bar, max. 80 bar
- Weight: 16.25 kg
- Installation according to data sheet D183
- Operating Manual WM-020-369-xx-xx

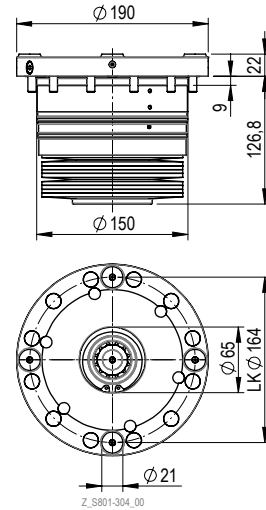

- Cylinder screws with hexagon socket M8 x 25mm S931-389, enclosed separately
 - Screw covers M8 055-146-05, enclosed separately
 - O-ring Ø 7.0 x 1.5mm S933-043, enclosed separately
 - Clamping pin Ø6.0 x 12mm S936-215, enclosed separately

Order number	Article designation	Function
S801-304	SE Z3 H 300 D190 TW NP DH	with third-hand function (DH)

▶ Third-hand function (DH) – see info page 17

STARK.balance.3 D190, installation - AG



Fast closing clamp made of high-quality tool steel

- Installation module Ø 190 mm, Twister with blow-out via 4 support islands (Ø 21 mm)
- Element with equaliser (floating area in one axis ± 0.75 mm)
- Hydraulic single acting
- with clamping, release and seat check
- with third-hand function (DH)

Properties

- Retention force: 38,000 N
- Insertion force: 38,000 N
- Pressure: min. 38 bar, max. 80 bar
- Weight: 16.25 kg
- Installation according to data sheet D183
- Operating Manual WM-020-369-xx-xx

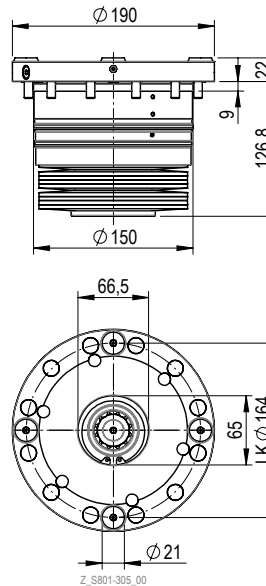

- Cylinder screws with hexagon socket M8 x 25mm S931-389, enclosed separately
 - Screw covers M8 055-146-05, enclosed separately
 - O-ring Ø 7.0 x 1.5mm S933-043, enclosed separately
 - Clamping pin Ø6.0 x 12mm S936-215, enclosed separately

Order number	Article designation	Function
S801-305	SE Z3 H 300 D190 TW AG DH	with third-hand function (DH)

▶ Third-hand function (DH) – see info page 17

STARK.balance.3 D190, installation - OZ



Fast closing clamp made of high-quality tool steel

- Installation module \varnothing 190 mm, Twister with blow-out via 4 support islands (\varnothing 21 mm)
- Element without centring (circumferential floating area ± 0.75 mm)
- Hydraulic single acting
- with clamping, release and seat check
- with third-hand function (DH)

Properties

- Retention force: 38,000 N
- Insertion force: 38,000 N
- Pressure: min. 38 bar, max. 80 bar
- Weight: 16.25 kg
- Installation according to data sheet D183
- Operating Manual WM-020-369-xx-xx

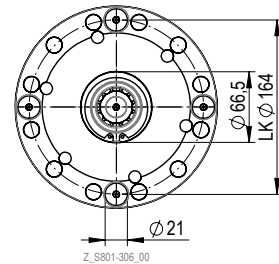
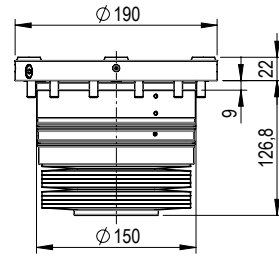

Z_S801-306_00

- Cylinder screws with hexagon socket M8 x 25mm S931-389, enclosed separately
 - Screw covers M8 055-146-05, enclosed separately
 - O-ring \varnothing 7.0 x 1.5mm S933-043, enclosed separately
 - Clamping pin \varnothing 6.0 x 12mm S936-215, enclosed separately

Order number	Article designation	Function
S801-306	SE Z3 H 300 D190 TW OZ DH	with third-hand function (DH)

► Third-hand function (DH) – see info page 17

BALANCE.3 DIRECT CLAMPING ELEMENTS

STARK.balance.3 D190, installation - NP



Fast closing clamp made of high-quality tool steel

- Installation module \varnothing 190 mm with raised support ring for direct clamping
- Element with zero point
- Hydraulic single acting
- with clamping, release and seat check
- with third-hand function (DH)

Properties

- Retention force: 38,000 N
- Insertion force: 38,000 N
- Pressure: min. 38 bar, max. 80 bar
- Weight: 17.15 kg
- Installation according to data sheet D183
- Operating Manual WM-020-369-xx-xx

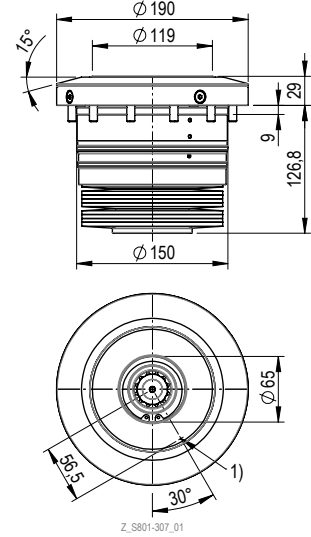

1) Seat check
- Cylinder screws with hexagon socket M8 x 25 mm S931-389, enclosed separately
- O-ring \varnothing 7.0 x 1.5 mm S933-043, enclosed separately
- Clamping pin \varnothing 6.0 x 12 mm S936-215, enclosed separately

Z_S801-307_01

Order number	Article designation	Function
S801-307	SE Z3 H 300 D190 EH NP DH	with third-hand function (DH)

► Third-hand function (DH) – see info page 17

STARK.balance.3 D190, installation - AG



Fast closing clamp made of high-quality tool steel

- Installation module \varnothing 190 mm with raised support ring for direct clamping
- Element with equaliser (floating area in one axis ± 0.75 mm)
- Hydraulic single acting
- with clamping, release and seat check
- with third-hand function (DH)

Properties

- Retention force: 38,000 N
- Insertion force: 38,000 N
- Pressure: min. 38 bar, max. 80 bar
- Weight: 17.15 kg
- Installation according to data sheet D183
- Operating Manual WM-020-369-xx-xx

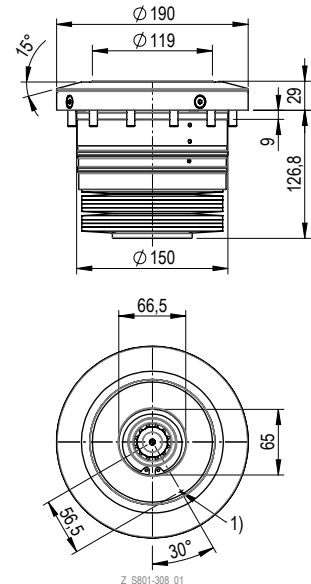

1) Seat check
- Cylinder screws with hexagon socket M8 x 25 mm S931-389, enclosed separately
- O-ring \varnothing 7.0 x 1.5 mm S933-043, enclosed separately
- Clamping pin \varnothing 6.0 x 12 mm S936-215, enclosed separately

Z_S801-308_01

Order number	Article designation	Function
S801-308	SE Z3 H 300 D190 EH AG DH	with third-hand function (DH)

► Third-hand function (DH) – see info page 17

STARK.balance.3 D190, installation - OZ



Fast closing clamp made of high-quality tool steel

- Installation module \varnothing 190 mm with raised support ring for direct clamping
- Element without centring (circumferential floating area ± 0.75 mm)
- Hydraulic single acting
- with clamping, release and seat check
- with third-hand function (DH)

Properties

- Retention force: 38,000 N
- Insertion force: 38,000 N
- Pressure: min. 38 bar, max. 80 bar
- Weight: 17.15 kg
- Installation according to data sheet D183
- Operating Manual WM-020-369-xx-xx

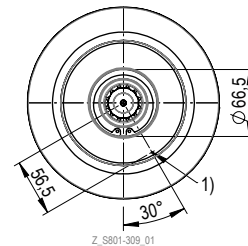
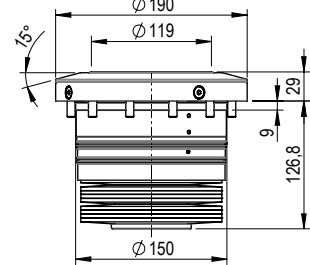

Z_S801-309_01

- 1) Seat check
 - Cylinder screws with hexagon socket M8 x 25 mm S931-389, enclosed separately
 - O-ring \varnothing 7.0 x 1.5 mm S933-043, enclosed separately
 - Clamping pin \varnothing 6.0 x 12 mm S936-215, enclosed separately

Order number	Article designation	Function
S801-309	SE Z3 H 300 D190 EH OZ DH	with third-hand function (DH)

► Third-hand function (DH) – see info page 17

Application example - Milling with 4-sided machining

4-fold STARK quick-release plate with STARK.balance.2 elements and optical clamping control

Retractable nipple with elevation, screwed into M20 thread on flat surface

Thanks to the high pull-in force of the STARK.balance elements, even heavy machining of high castings is possible.

Secure clamping is ensured by the optical clamping control (see p. 16) - using a lateral probe pin (optional) on the optical clamping control, the machine can check via a 3D probe whether clamping is secure.



clamped



released

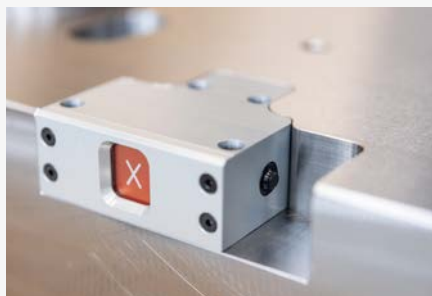

Application example – turning machines

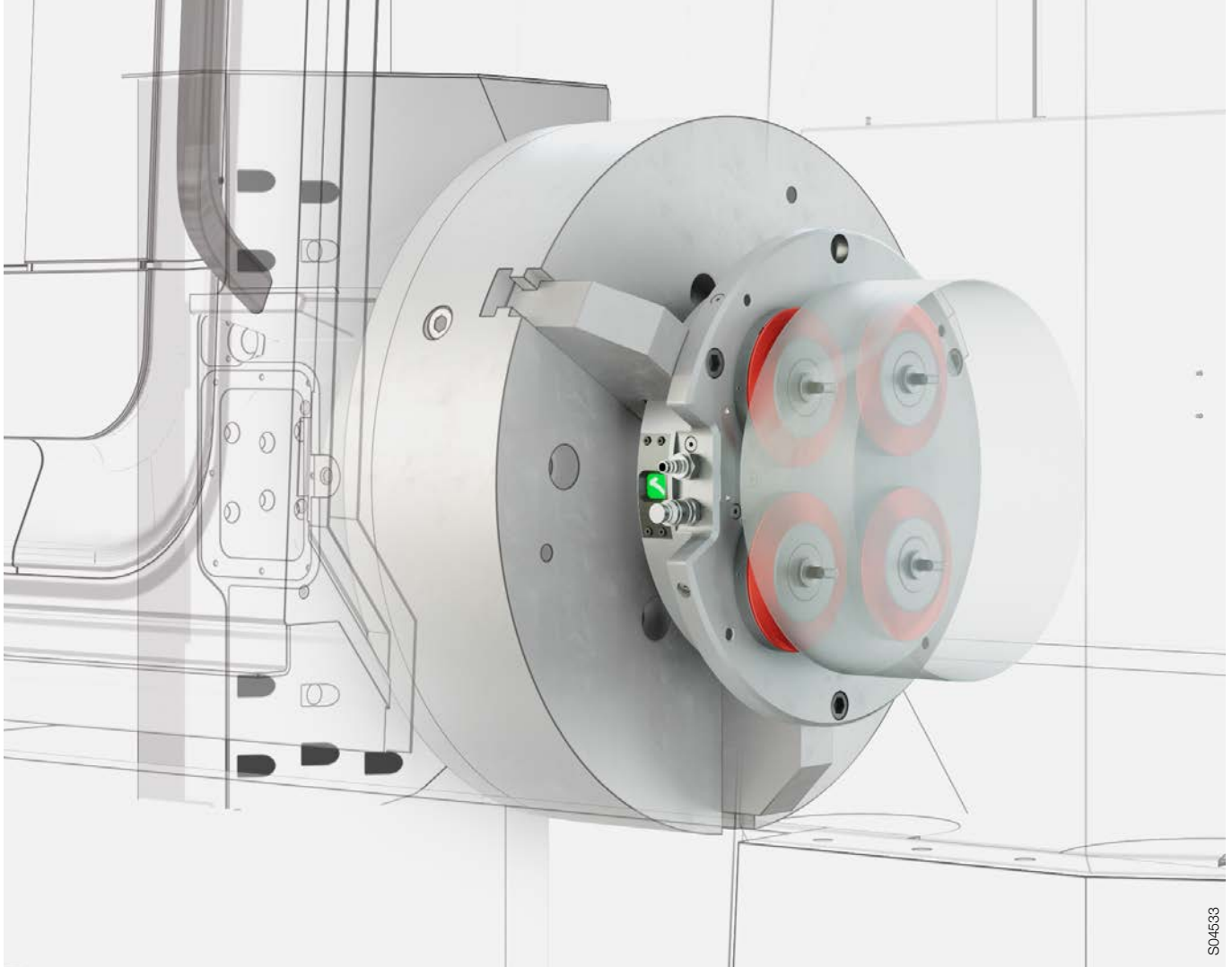

S04533

Direct workpiece clamping for turning machines

- Zero point clamping system with 4 STARK.balance elements (S801-20x and S201-30x)
- Optical clamping control
- Asymmetrical arrangement of elements – position orientation
- 5 ½ sides accessible for processing
- Simple conversion – clamped in jaw chuck, secured with screws

System options

- Elements with third-hand function
- Clamping control – via the machine control system or optical clamping control
- Seat check possible
- Direct assembly on spindle nose possible
- Control via rotary transmission possible

Application example – milling machines

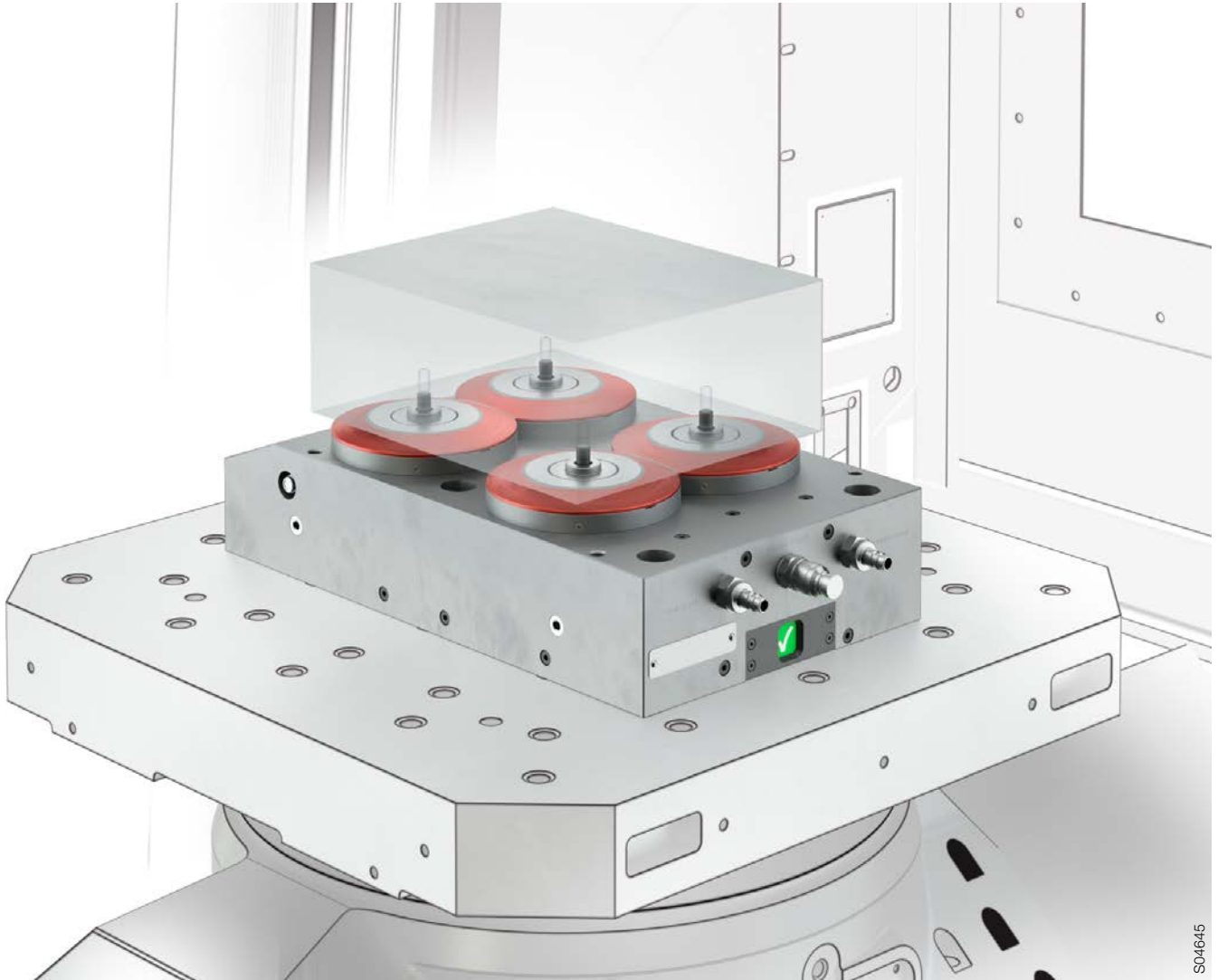

S04645

Typical application for milling machines

- Zero point clamping system with 4 STARK.balance elements (S801-20x and S801-30x)
- Optical clamping control
- Flattened STARK.balance for narrower spacing
- Raised or bevelled fast closing plate for optimal 5-axis processing
- 5 sides with unrestricted access

System options

- Elements with third-hand function
- Clamping control – via the machine control system or optical clamping control
- Seat check possible
- Adapted fast closing plate and elements for optimum customer benefit

SURFACE-MOUNTED ELEMENT

STARK.balance.2 D135, surface-mounted element



Surface-mounted element Ø 200 mm incl. STARK.classic.2 NG (S804-538) and STARK.balance.2 (S801-20x)

- Installation module Ø 135 mm with raised support ring for direct clamping
- Hydraulic single acting
- with clamping, release and seat check

Properties

- Retention force: 38,000 N
- Insertion force: 38,000 N
- Pressure: min. 60 bar, max. 80 bar
- Weight: 29.9 kg
- Operating Manual WM-020-369-xx-xx

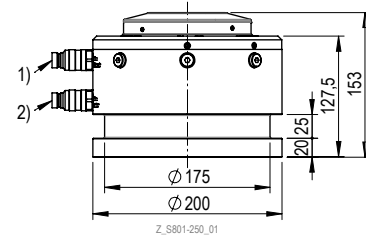

1) STARK.balance.2 release connection
2) STARK.classic.2 release connection

Z_S801-250_01

Order number	Article designation	Element	Element
S801-250	SA Z2 H 200 D135 EH NP	Zero point element	STARK.balance.2 NP (S801-207)
S801-251	SA Z2 H 200 D135 EH AG	Element with equaliser ± 0.75 mm	STARK.balance.2 AG (S801-208)
S801-252	SA Z2 H 200 D135 EH OZ	Element without centring ± 0.75 mm	STARK.balance.2 OZ (S801-209)

STARK.balance.3 D190, surface-mounted element



Surface-mounted element Ø 190 mm incl. STARK.classic.3 NG (S807-212) and STARK.balance.3 (S801-30x)

- Installation module Ø 190 mm with raised support ring for direct clamping
- Hydraulic single acting
- with clamping, release and seat check
- DH control (third hand function)

Properties:

- Retention force: 38,000 N
- Insertion force: 38,000 N
- Pressure: min. 40 bar, max. 80 bar
- Weight (total): 42.6 kg
- Operating Manual WM-020-369-xx-xx

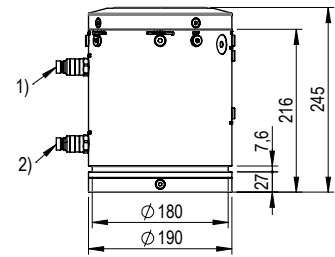

1) STARK.balance.3 release connection
2) STARK.classic.3 release connection

Z_S801-340_341_342_00

Order number	Article designation	Element	Element
S801-340	SA Z3 H 300 D190 EH NP DH	Zero point element	STARK.balance 3 NP (S801-307)
S801-341	SA Z3 H 300 D190 EH AG DH	Element with equaliser ± 0.75 mm	STARK.balance 3 AG (S801-308)
S801-342	SA Z3 H 300 D190 EH OZ DH	Element without centring ± 0.75 mm	STARK.balance 3 OZ (S801-309)

Design

Spacing, flexible application

- Fast and flexible positioning
- Height advantage - Height can be customised
- Bottom side with clamping edge for clamping claws or optionally with STARK.classic

- 1 Screw-on situation depending on application
- 2 Retractable nipple with zero point
- 3 STARK.balance.2 NP (S801-207) or STARK.balance.2 AG (S801-208) or STARK.balance.2 OZ (S801-209)
- 4 STARK.balance.2 release
- 5 STARK.classic.2 NG release
- 6 Release and clamping control
- 7 STARK.classic.2 NG (S804-538)
- 8 Retractable nipple with zero point (S804-470)

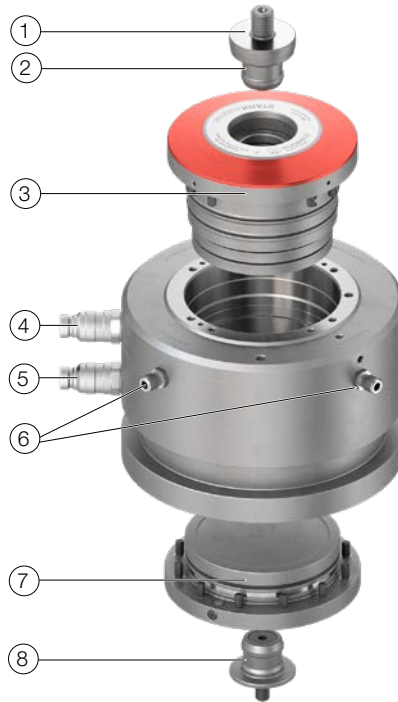

INFO

STARK.spheric

Tension-free clamping

Equalisation of curved surfaces for tension-free clamping

- Equalises $\pm 5^\circ$ angles without changing the zero point in position
- Fast and flexible positioning without loss of the zero point



INFO

STARK.balance surface-mounted element functionality

Do you want to gain height?

All STARK zero point clamping systems are also available as surface-mounted elements. In addition, you have the option of adapting the retractable nipple to ensure that nothing "gets in the way" when processing.

- 1 Workpiece
- 2 Retractable nipple mounted
- 3 Retractable nipple
- 4 STARK.balance surface-mounted element
- 5 Base plate

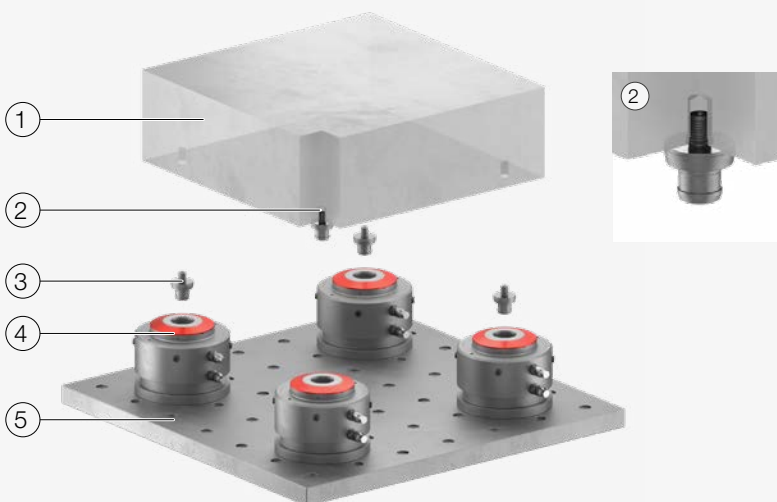

3-fold clamping example

- STARK.spheric with zero point equalises the angle $\pm 5^\circ$ in all directions without changing the position of the zero point
- STARK.spheric with equaliser equalises the angle $\pm 5^\circ$ in all directions as well as a shift of $\pm 1.5\text{mm}$ in one direction
- STARK.spheric without centring equalises the angle $\pm 5^\circ$ in all directions and a shift of $\pm 1.5\text{mm}$ in all directions

RETRACTABLE NIPPLE FOR BALANCE.2

STARK.classic.2 retractable nipple- NP



Retractable nipple suitable for fast closing clamps of the STARK.classic.2 and STARK.balance.2 Standard and Twister versions.

- Retractable nipple with zero point
- with fit
- Material: Tool steel
- Installation according to data sheet D029-2

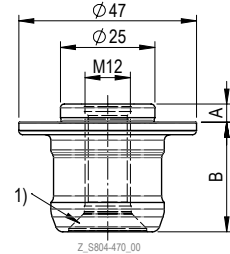

1) Countersink for M10 screw

Order number	Article designation	Area of application*	Thread (M)	Collar (A)	Length (B)	Weight
S804-470	EB C2 NP 250 12 048	STARK.balance.2 Standard	M12	4.8mm	46.0mm	0.17
S804-474	EB C2 NP 250 12 148	STARK.balance.2 Standard / Twister	M12	14.8mm	46.0mm	0.19

* See Combination options & tolerance range on page 14

STARK.balance.2 retractable nipple- NP



Retractable nipple for STARK.balance direct clamping fast closing clamps

- Retractable nipple with zero point
- with fit
- Material: Tool steel
- Installation according to data sheet D029-2

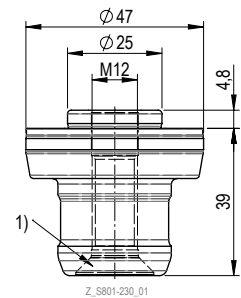

1) Countersink for M10 screw

Order number	Article designation	Thread (M)	Collar	Length	Weight
S801-230	EL Z2 NP 250 12 048	M12	4.8 mm	39.0 mm	0.3kg

STARK.balance.2 retractable nipple- NP



Retractable nipple for STARK.balance direct clamping fast closing clamps

- Retractable nipple with zero point
- without fit
- Material: Tool steel

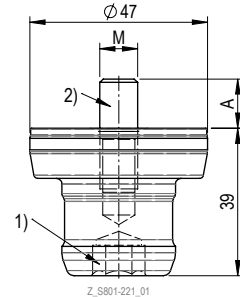

1) Width across flats SW 12

Order number	Article designation	Thread (M)	Tightening torque	Thread length (A)	Length	Weight
S801-221	EL Z2 NP 000 10 000 EG	M10	45 Nm	13 mm	39.0 mm	0.30 kg
S801-222	EL Z2 NP 000 12 000 EG	M12	60 Nm	12 mm	39.0 mm	0.30 kg
S801-223	EL Z2 NP 000 16 000 EG	M16	100 Nm	20 mm	39.0 mm	0.30 kg
S801-224	EL Z2 NP 000 20 000 EG	M20	110 Nm	26 mm	39.0 mm	0.40 kg
S801-225	EL Z2 NP 000 24 000 EG	M24	123 Nm	33 mm	39.0 mm	0.40 kg

INFO

Retractable nipple selection & support surface design

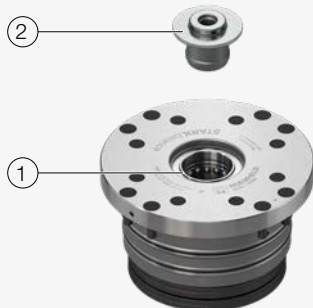

- 1 Element Standard / Standard DH
- 2 Retractable nipple (S804-470)

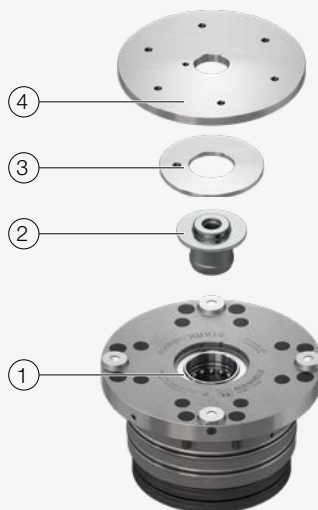

- 1 Element Twister / Twister DH
- 2 Retractable nipple (S804-474)
- 3 Spacer with O-ring
- 4 Support disc

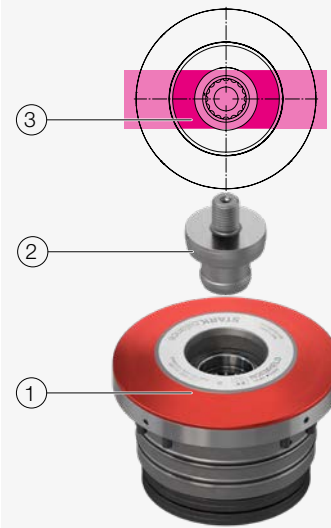

- 1 Direct clamping / direct clamping DH element
- 2 Retractable nipple (S801-22x, S801-230)
- 3 For direct clamping, ensure plane support on the support surface (> 50 %)



RETRACTABLE NIPPLE BALANCE.3

STARK.classic.3 retractable nipple - NP



Retractable nipple suitable for fast closing clamps of the STARK.classic.3 and STARK.balance.3 Standard and Twister versions.

- Retractable nipple with zero point
- with fit
- Material: Tool steel
- Installation according to data sheet D029-2

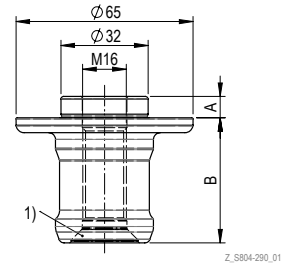

Z_S804-290_01

1) Countersink for M12 screw

Order number	Article designation	Area of application*1	Thread (M)	Collar (A)	Length (B)	Weight
S804-290	EB C3 NP 320 16 078	Standard	M16	7.8 mm	46.0 mm	0.40 kg
S04156	EB C3 NP 320 16 248	Standard / Twister With hardened support disc*2	M16	24.8 mm	46.0 mm	0.48 kg

*1 See Combination options & tolerance range on page 15

*2 Hardened support disc – see page 40

STARK.balance.3 retractable nipple - NP



Retractable nipple for STARK.balance direct clamping fast closing clamps

- Retractable nipple with zero point
- with fit
- Material: Tool steel
- Installation according to data sheet D029-2

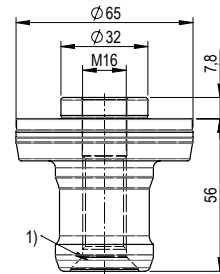

Z_S801-330_01

1) Countersink for M16 screw

Order number	Article designation	Thread (M)	Collar	Length	Weight
S801-330	EL Z3 NP 320 16 078	M16	7.8 mm	56.0 mm	0.64 kg

STARK.balance.3 retractable nipple - NP



Retractable nipple for STARK.balance direct clamping fast closing clamps

- Retractable nipple with zero point
- without fit
- Material: Tool steel

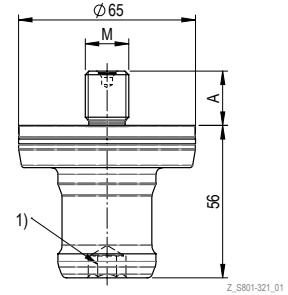

1) Width across flats SW 12

Order number	Article designation	Thread (M)	Tightening torque	Thread length (A)	Length	Weight
S801-321	EL Z3 NP 000 16 000 EG	M16	175 Nm	20 mm	56.0 mm	0.69 kg
S801-322	EL Z3 NP 000 20 000 EG	M20	193 Nm	26 mm	56.0 mm	0.72 kg
S801-323	EL Z3 NP 000 24 000 EG	M24	212 Nm	33 mm	56.0 mm	0.77 kg
S801-324	EL Z3 NP 000 30 000 EG	M30	240 Nm	36 mm	56.0 mm	0.85 kg
S801-325	EL Z3 NP 000 36 000 EG	M36	265 Nm	42 mm	56.0 mm	0.98 kg

NIPPLE FASTENING

Nipple fastening D



For mounting the retractable nipple according to fastening option "D"

- Enables the nipple fastening bore hole to be produced from above in one clamping procedure
- Mounting key or face spanner recommended for holding in place
- Installation according to data sheet D029-2
- Operating Manual WM-020-332-xx-xx

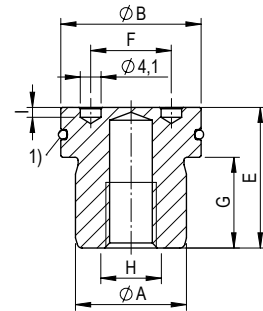

Z_Nippelbefestigung_D_00

1) O-ring included in scope of delivery

Order number	Article designation	Size	ØA*	ØB	E	F	G	H	l	Weight
S804-267	NB 30 22 25 12 M10 NI D	ba.2	Ø25.0mm	Ø29.8mm	21.9mm	24.0mm	12.0mm	M10 × 13	3.0mm	0.09kg
S804-262	NB 38 28 32 18 M12 NI D	ba.3	Ø32.0mm	Ø37.8mm	27.9mm	24.0mm	18.0mm	M12 × 18	2.0mm	0.18kg
S804-263	NB 30 28 25 18 M12 NI D	ba.3	Ø25.0mm	Ø29.8mm	27.9mm	24.0mm	18.0mm	M12 × 18	2.0mm	0.09kg

* ØA should correspond to the collar Ø of the retractable nipple

Nipple fastening E



For mounting the retractable nipple according to fastening option "E"

- Enables the nipple fastening bore hole to be produced from above in one clamping procedure
- Installation according to data sheet D029-2
- Operating Manual WM-020-332-xx-xx

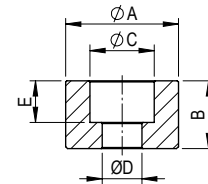

Z_Nippelbefestigung_E_00

Order number	Article designation	Size	ØA	B	ØC	ØD	E	Weight
S804-266-01	NB 30 18 00 00 F12 NI E	ba.2	Ø29.8mm	17.9mm	Ø18.5mm	Ø12.5mm	12.5mm	0.06kg
S03651	NB 44 27 00 00 F16 NI E	ba.3	Ø43.8mm	26.6mm	Ø26.0mm	Ø17.0mm	16.6mm	0.26kg

Nipple fastening E.1



For mounting the retractable nipple according to fastening option "E.1"

- Enables the nipple fastening bore hole to be produced from above in one clamping procedure
- Mounting key or face spanner recommended for holding in place
- Installation according to data sheet D029-2
- Operating Manual WM-020-332-xx-xx

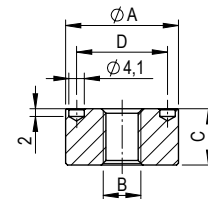

Z_Nippelbefestigung_E.1_00

Order number	Article designation	Size	ØA	B	C	D	Weight
S804-266	NB 30 15 00 00 M10 NI E1	ba.2	Ø29.8mm	M10	14.9mm	24.0mm	0.05kg
S804-264	NB 38 18 00 00 M12 NI E1	ba.3	Ø37.8mm	M12	17.9mm	24.0mm	0.15kg
S804-265	NB 30 15 00 00 M12 NI E1	ba.3	Ø29.8mm	M12	17.9mm	24.0mm	0.09kg

INFO

Retractable nipple fastening versions

Version A

For applications where nipple bores are not permitted on the surface (e.g. pallet top) or for direct workpiece clamping.

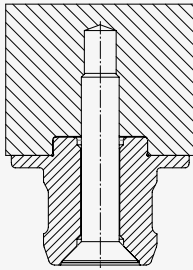

Version B

Simple nipple fastening from above.

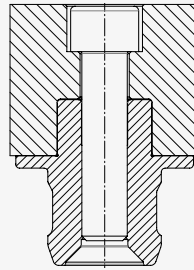

Version C

Ideal fastening version for clamping in laterally inverted manufacturing. Highest level of accuracy is guaranteed because the retractable nipples are fastened in the same locating bore.

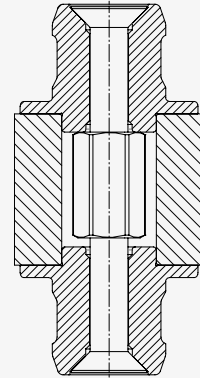

The fitting bores for the retractable nipples and all necessary positioning bores on the pallet can be produced in one operation. This results in the highest level of accuracy of the positions to each other. Mounting version D is additionally sealed by an O-ring.

Version D

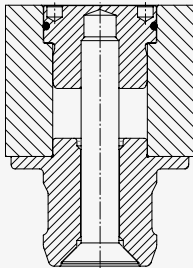

Version E

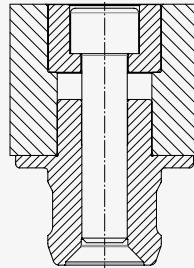

Version E.1

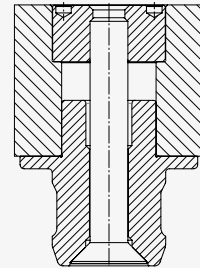

Key for nipple fastening D & E.1



For assembly and disassembly of the retractable nipples according to versions "D & E.1"

- Width across flats SW22
- For tightening torque, see retractable nipple installation data sheets

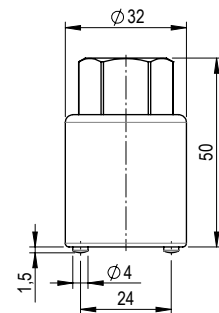

Z_S804-254_00

Order number	Article designation	Dimensions	Weight
S804-254	Key for nipple fastening D and E.1	Ø32 mm / 50 mm	0.16 kg

ACCESSORIES

Spacer with O-ring



For height compensation and sealing the centre bore for STARK.balance.2 Twister and STARK.balance.3 Twister

- Very precise seat check (up to 0.01 mm) possible, as air can only escape at the 4 support islands due to the sealing of the centre bore

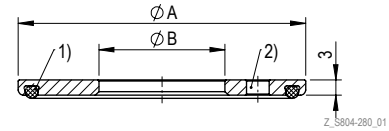

1) Sealing ring S93-231-01 (NG.2) / S933-439 (NG.3)
2) Indexing bore

Order number	Article designation	Area of application/special feature	A	B	Weight
S804-280	DS 057 25 030 B	ba.2 Twister	57 mm	25 mm	0.05 kg
S804-060	DS 078 32 030 B	ba.3 Twister	78 mm	32 mm	0.09 kg

Support disc made of hardened steel - balance.2



For the use of non-hardened machine pallet surfaces for STARK.balance.2 Twister

- High wear resistance for non-hardened machine pallet surfaces
- Installation according to data sheet D033 (sheet 33)

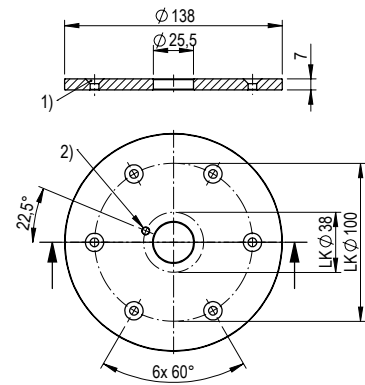

Z_S804-281-02_01

1) Countersink for M5 screw
2) Indexing bore for M4 / DIN427 shaft screw

Order number	Article designation	Area of application/special feature	Surface	Collar	Weight
S804-281-02	AS D138 25 70 A	ba.2 Twister	ground on both sides	Ø25 mm	0.78 kg

Support disc made of hardened steel - balance.3



For the use of non-hardened machine pallet surfaces for STARK.balance.3 Twister

- High wear resistance for non-hardened machine pallet surfaces
- Installation according to data sheet D033 (sheet 10)

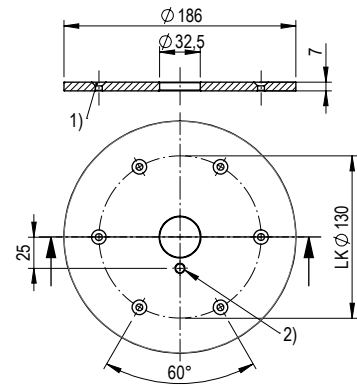

Z_S03643_00

1) Countersink for M5 screw
2) Indexing bore for M5 DIN 427/ISO 2342 shaft screw
- Countersunk screws M5 x 12 S931-368 included in scope of delivery

Order number	Article designation	Area of application/special feature	Surface	Collar	Weight
S03643	AS D186 32 70 A	ba.3 Twister	ground on both sides	Ø32 mm	1.42 kg

Screw cover

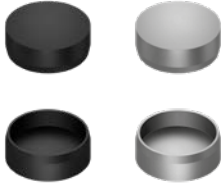

Screw cover suitable for the retractable nipples or fast closing clamps of the STARK.balance family

Order number	Article designation	Size	Version	Weight
S999-428	Plastic cover for M5	ba.2	M5 Ø 10×3.5mm	0.001 kg
S999-408	Plastic cover for M6	ba.2	M6 Ø 11×3.3mm	0.001 kg
S704-231	Stainless steel screw cover for M6	ba.3	M6 Ø 11.5×3.0mm	0.001 kg
S055-146-05	Stainless steel screw cover for M8	ba.3	M8 Ø 15×3.0mm	0.001 kg

INFO

Application example

Application example; STARK.balance.2 Twister with spacer and support disc

- 1) Nipple fastening
- 2) Fixing screws for retractable nipple
- 3) Fixing screw for hardened support disc
- 4) Hardened support disc
- 5) Spacer with O-ring
- 6) Retractable nipple
- 7) STARK.balance.2 Twister

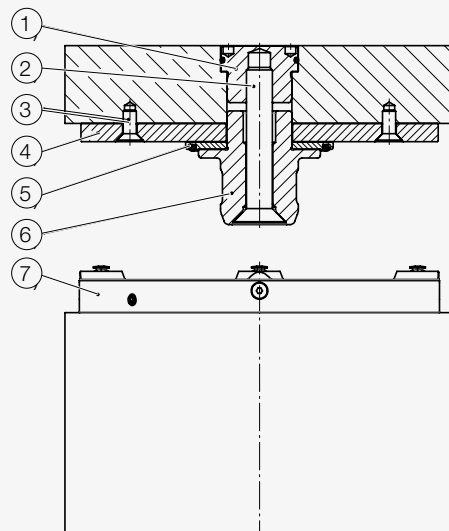

RECORD pressure booster



The RECORD pressure booster converts air pressure into the required hydraulic system pressure for actuating the STARK.balance fast closing clamps.

- Version with 40bar and 80 bar
- Air pressure 6 bar
- Weight 8.80 kg
- Operating Manual WM-020-062-xx-xx

► Pressure booster can be extended to DH with article S804-427

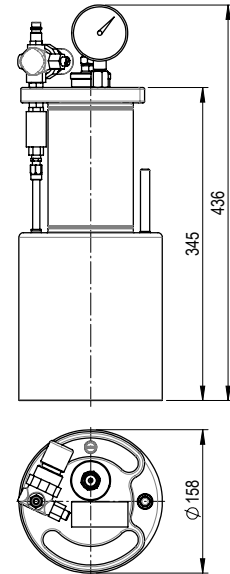

Z_S804-412_00

Order number	Article designation	Area of application/special feature	Oil volume
S804-411	"RECORD" pressure booster 40 bar	Control of max. 2 STARK.balance.3 up to max. 40 bar (system pressure)	0.3 l
S804-412	"RECORD" pressure booster 80 bar	Control of max. 5 STARK.balance.2 up to max. 80 bar (system pressure)	0.148 l

COMFORT pressure booster



The pressure booster is used to release single-acting clamping systems. The booster converts compressed air into hydraulic pressure and is suitable for application areas of 80 bar.

- Version with 40bar and 80 bar
- Air pressure 6 bar
- Weight 27.30 kg
- Operating Manual WM-020-334-xx-xx

► Pressure booster can be extended to DH with article S804-427

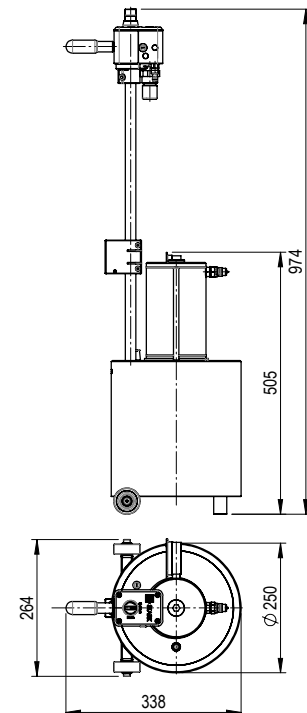

Z_S804-433_00

Order number	Article designation	Area of application/special feature	Oil volume
S804-432	"COMFORT" booster 40 bar	Control of max. 7 STARK.balance.3 up to max. 40 bar (system pressure)	1,0l
S804-433	"COMFORT" booster 80 bar	Control of max. 20 STARK.balance.2 up to max. 80 bar (system pressure)	0,5 l

Hydraulic hose with couplings



Hydraulic hose with hydraulic plug-in coupling on both sides.

Used to connect between pressure booster and fast closing plate or surface-mounted element

- Max. pressure 300 bar

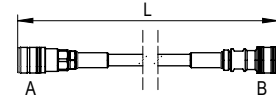

Z_S704-153_00

Order number	Article designation	Couplings A/B	Length L	Weight
S704-150	Hydraulic hose set	A/B: Standard (S952-044)	1.5 m	0.63 kg
S704-151	Hydraulic hose set	A: Leak-free (S952-177) / B: Standard (S952-044)	1.5 m	0.63 kg
S704-152	Hydraulic hose set	A/B: Standard (S952-044)	3.0 m	0.85 kg
S704-153	Hydraulic hose set	A: Leak-free (S952-177) / B: Standard (S952-044)	3.0 m	0.85 kg

Pedal controller

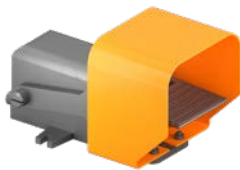

Pedal controller for controlling the pressure booster

- Control of the pressure booster via foot controller
- The pressure booster does not have to be located in the immediate vicinity
- Both hands are free for loading or for removing the workpieces to be processed
- Weight 1.5 kg

Order number	Article designation
S804-419	Pedal controller for pressure booster (incl. pneumatic hose and screw-in connections)

DH pedal controller (third hand function)

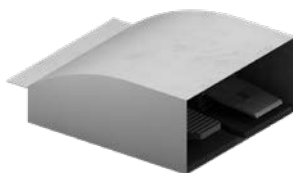

The special pressure control (actuation) of the fast closing clamps allows the workpiece, pallet or device to be easily engaged. Feed, engage and clamp.

- For a vertical clamping position or for feeding by robots or handling systems
- Weight 4 kg

Order number	Article designation
S804-427	Pedal controller for pressure booster (incl. pneumatic hose and screw-in connections)

Air-hydraulic clamping pump



Air-hydraulic pump (40 bar)
Actuation via integrated foot pedal
Oscillating air/oil pressure intensifier

- Pneumatic coupling plug
- Pressure gauge (0-60 bar)
- Oil volume 2.4l
- Hydraulic hose set S952-138 leakage oil-free
- Operating manual WM-020-410-xx

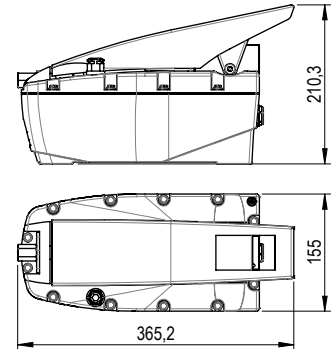

Z_S952-314_00

Order number	Article designation
S803-413	Air-hydraulic pump 40 bar with pressure gauge

Specification dimension tester



The specification dimension tester is used to check the specification dimension according to the operating manual of the respective element types.

The DH specification dimension tester is used to check the function of the DH position (third-hand function) and its setting

- Supplied in a plastic case
- Incl. calibration piece
- Operating Manual WM-020-349-xx-xx

S504-022

Order number	Article designation
S504-022	Specification dimension tester for STARK.balance.2 (Standard, Twister)
S504-029	Specification dimension tester for STARK.balance.2 (direct clamping)
S504-032	Specification dimension tester DH for STARK.balance.2 (Standard, Twister)
S504-036	Specification dimension tester DH for STARK.balance.2 (direct clamping)
S504-043	Specification dimension tester for all STARK.balance.3 versions
S504-044	Specification dimension tester DH for all STARK.balance.3 DH versions

Mechanical insertion force tester



The insertion force tester is used to reliably check the insertion force of the STARK fast closing clamps.

The insertion force may change depending on actuation cycles and wear. As a result, the specified insertion force is no longer achieved and the machining forces are no longer fully absorbed by the zero point clamping system. As a preventive measure, STARK recommends regular inspection of the clamping elements (see operating manual).

S504-000

Order number	Article designation	Weight
S504-002	Mechanical insertion force tester STARK.balance.2 (Standard, Twister)	7.1 kg
S504-004	Mechanical insertion force tester STARK.balance.3 (Standard, Twister)	8.6 kg
S504-005	Mechanical insertion force tester STARK.balance.2 (direct clamping)	5.8 kg
S504-042	Mechanical insertion force tester STARK.balance.3 (direct clamping)	6.1 kg
S504-000	Rental case: Mechanical insertion force tester STARK.balance.2/3	-

INFO

Mechanical insertion force tester



Supplied in a practical plastic case (L390 × W280 × H110)



Insertion force tester (1) with calibration certificate and operating manual in the plastic box, with support ring (2), adapter retractable nipple (3) and spacer (4)



STARK.balance order number directory

S03643	40	S801-203	19	S801-250	32	S804-060	40
S03651	38	S801-204	18	S801-251	32	S804-254	39
S04156	36	S801-205	18	S801-252	32	S804-262	38
S055-146-05	41	S801-206	19	S801-301	24	S804-263	38
S504-000	45	S801-207	22	S801-302	24	S804-264	38
S504-002	45	S801-208	22	S801-303	25	S804-265	38
S504-004	45	S801-209	23	S801-304	26	S804-266	38
S504-005	45	S801-210	22	S801-305	26	S804-266-01	38
S504-022	44	S801-211	22	S801-306	27	S804-267	38
S504-029	44	S801-212	23	S801-307	28	S804-280	40
S504-032	44	S801-213	20	S801-308	28	S804-281-02	40
S504-036	44	S801-214	20	S801-309	29	S804-290	36
S504-042	45	S801-215	21	S801-321	37	S804-411	42
S504-043	44	S801-216	20	S801-322	37	S804-412	42
S504-044	44	S801-217	20	S801-323	37	S804-419	43
S704-150	43	S801-218	21	S801-324	37	S804-427	43
S704-151	43	S801-221	35	S801-325	37	S804-432	42
S704-152	43	S801-222	35	S801-330	36	S804-433	42
S704-153	43	S801-223	35	S801-340	32	S804-470	34
S704-231	41	S801-224	35	S801-341	32	S804-474	34
S801-201	18	S801-225	35	S801-342	32	S999-408	41
S801-202	18	S801-230	34	S803-413	44	S999-428	41

A COMPANY OF THE
ROEMHELD GRUPPE

STARK Spannsysteme

The ROEMHELD Group consists of 5 companies at locations in Germany and Austria, each with different products and orientations. With numerous subsidiaries, sales partners and service companies on all continents and in more than 50 countries, rapid and intensive customer support is provided in the mechanical engineering, medical technology, automotive, aviation and agricultural industries.

As part of the ROEMHELD Group, STARK benefits from the security and experience of a family-run traditional company as well as from the worldwide sales and service network. At the same time, this background provides the independence to pursue dynamic and innovative goals for new market-driven developments and customer-specific solutions with which STARK maintains its leading technological position.



ROEMHELD
HILMA ■ STARK

STARK Spannsysteme

A company of the ROEMHELD Group

STARK Spannsysteme GmbH
Römergrund 14 | 6830 Rankweil
Austria

+43 5522 37 400 - 0
info@stark-roemheld.com

stark-roemheld.com