

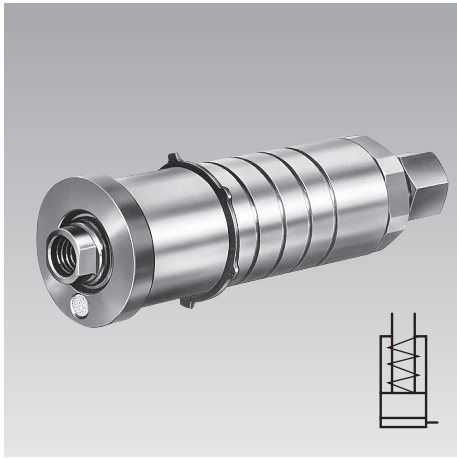
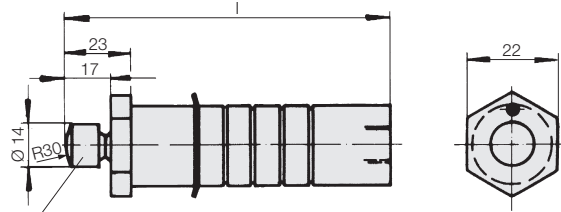

Universal Clamping Cylinders

single acting with spring return,
 max. operating pressure 200 / 500 bar

Type 1309020

Contact bolt 3542085 is included in our delivery

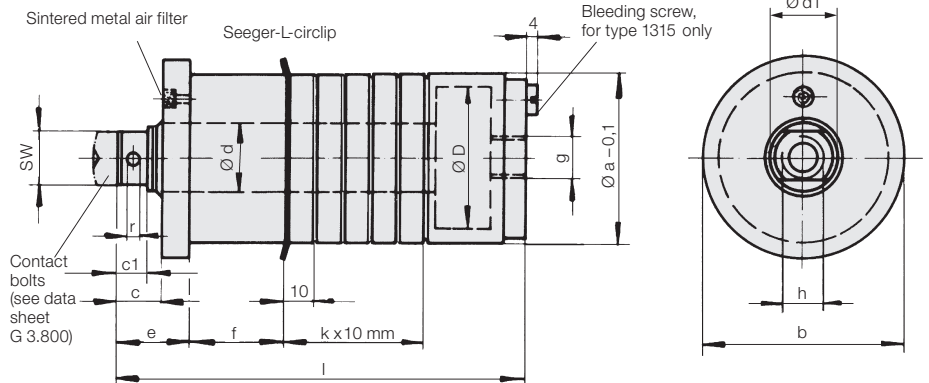
Typ 1313020, 1315020, 1316060

Description

Universal clamping cylinders are particularly suited for clamping fixtures designed to hold various sizes of workpieces (parts families). They can be mounted directly into the fixture wall or installed into horizontal or vertical mounting brackets which are available as accessories. Spacers and C-washers provide axial adjustment in increments of 10 mm.

Bleeding is effected via fitting connection or via bleeding screw for type 1316.

Material

Piston: casehardening steel, hardened
 Cylinder body: free cutting steel

Important notes

Penetration of aggressive cutting lubricants and coolants through the sintered metal air filter into the cylinder's interior should be avoided by appropriate arrangement or covering.

If required, a vent hose has to be connected and be placed in a protected position.

Operating conditions, tolerances and other data see data sheet A 0.100.

It is absolutely necessary to follow the instructions for venting of the spring area on data sheet G 0.110.

Piston Ø D	[mm]	10	25	40	50
Rod Ø d	[mm]	6	16	25	32
Stroke ± 1	[mm]	20	20	22	50
Clamping force 100 bar	[kN]	0.7	4.9	12.6	19.5
at max. operating pressure	[kN]	3.7	24.5	62.8	39.0
Max. operating pressure	[bar]	500	500	500	200
Spring return force, min.	[N]	28	140	270	390
Oil volume per 10 mm stroke	[cm ³]	0.78	4.91	12.56	19.63
Ø a	[mm]	20	35	60	60
b	[mm]	–	40	68	68
c	[mm]	–	9	11	11
Ø d1 x c1	[mm]	–	15x5	24x7	30,5x6,5
e	[mm]	–	16	19	19
f	[mm]	18.7	28.4	37.9	37.9
g		G 1/4	G 1/4	G 1/4	G 1/4
h x depth of thread	[mm]	–	M10x15	M16x25	M20x30
k		4 x	5 x	5 x	11 x
l ± 1	[mm]	111	123	138	194
r	[mm]	–	–	4	4
SW	[mm]	–	13	–	–
Weight	[kg]	0.3	0.75	2.0	2.5

Part no. **1309020** **1313020** **1315020** **1316060**

Article available on request

Application example

