



**ROEMHELD**  
HILMA ■ STARK



# HILMA.MCP

## Compact 5-axis clamping system

Jaw width 60 - 125 mm

WS 5.4501, WS 5.4502, WS 5.4503, WS 5.450Z



**ROEMHELD**  
HILMA ■ STARK



# STARK INNOVATIVE PROFICIENT INDIVIDUAL SAFE

The high-tech company STARK Spannsysteme was established in 1977 in Rankweil, Austria. It manufactures zero point clamping systems and vises of the highest quality and precision for international clients in the automotive, aviation and medical industries, for example.

STARK Spannsysteme products are a byword for minimal set-up times, faster production and high flexibility.

HILMA vises can be complemented and combined perfectly with STARK zero point clamping systems.

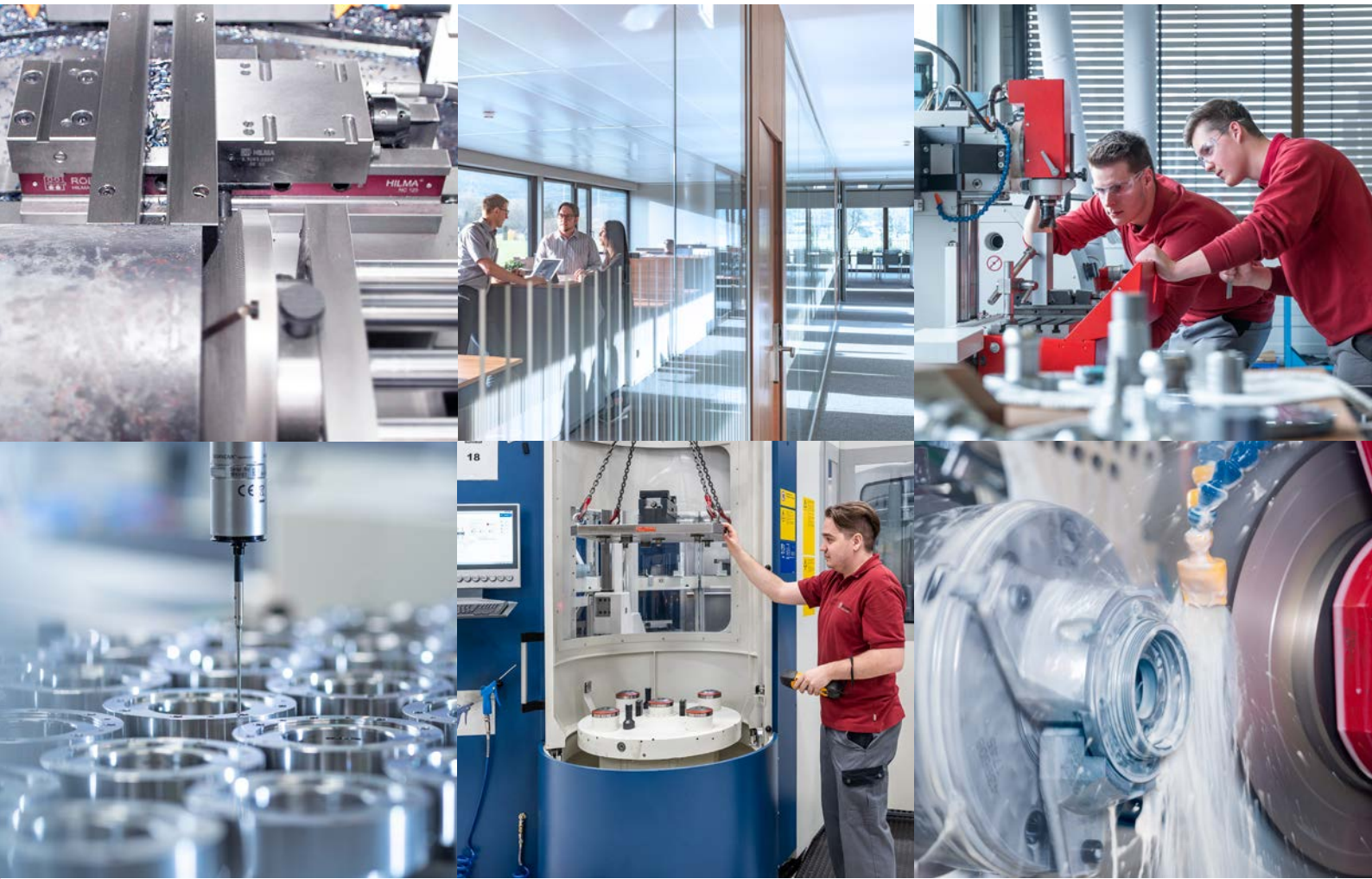

AUTOMOTIVE



AVIATION



MACHINE AND TOOL  
CONSTRUCTION



MEDICINE

# FOCUS ON INDUSTRIES & MARKETS.

Every customer has specific requirements. Our established and extensive industry expertise allows us to offer you the best solutions, services and products for sustainable and efficient use in your market.

# HILMA.MCP



HILMA.MCP



HILMA.UC



HILMA.SCS



HILMA.KNC



HILMA.SCT



HILMA.NC



HILMA.TS Vector



HILMA.DS



HILMA.TS TriStar



HILMA.ASE



HILMA.ASH



## HILMA Workholding systems

More productivity through

- Maximum flexibility in production
- Highest process reliability
- Reduced manufacturing costs through set-up time optimisation

## WS 5.4501 Workholding Systems HILMA.MCP

### clamping against the fixed jaw, mechanically operated jaw widths 60, 100 and 125 mm



#### Advantages

- Patented segment design
- Compact design
- High precision and accuracy of the manufactured workpieces by high rigidity
- High zero-point stability
- Sturdy design and good swarf protection
- Large jaw openings
- Extensive range of jaws
- Clamping of raw and finished parts without retrofitting
- Easy to maintain

#### Description

Workholding systems of the HILMA.MCP series excel by a very compact design and their patented segment design.

Thanks to the adjusting spindle arranged in the upper part of the housing, deformation in the base during clamping is reduced to a minimum. Thus, a high rigidity of the workholding system is obtained.

The patented segment design ensures a high degree of precision and stability. The guiding clearance is reduced to nearly zero. All essential components are made of hardened steel.

The workholding systems HILMA.MCP 100/125 are already prepared for the use on zero point clamping systems. For this purpose, there are location threads for retractable nipples at the bottom side of the housing. For workholding systems HILMA.MCP, a wide range of clamping jaws is available (see data sheet WS 5.450Z).

#### Customised versions

HILMA.MCP workholding systems can also be delivered as customised versions. For example in other lengths or with individual mounting holes.

Please contact us.

#### Consultation

Our experts will be pleased to advise you also on site, and work with you to find the optimum clamping solution.

Extensive information such as drawings and CAD models are available on request.

#### Technical data

Clamping principle: **clamping against the fixed jaw mechanically**  
with a torque wrench

Operation:

#### HILMA.MCP 60

Jaw width: 60 mm  
Clamping force\*: 15 kN at 60 Nm  
Clamping stroke: 30 mm  
Max. jaw opening: 6–150 mm

#### HILMA.MCP 100

Jaw width: 100 mm  
Clamping force\*: 25 kN at 90 Nm  
Clamping stroke: 50 mm  
Max. jaw opening: 6–204 mm

#### HILMA.MCP 125 K

Jaw width: 125 mm  
Clamping force\*: 40 kN at 180 Nm  
Clamping stroke: 101 mm  
Max. jaw opening: 6–215 mm

#### Operation

The movable clamping jaw is displaced by a threaded spindle which is also used to build-up the clamping force. A torque wrench is used for exact and reproducible clamping force adjustment.

#### \*Important note

The specified clamping forces apply to a clamping height (n) of 15 mm. For higher clamping heights, the clamping forces are reduced.

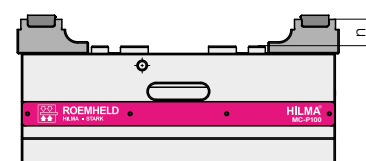

#### Application

The workholding systems HILMA.MCP are especially advantageous for 5-axis machining. The compact design allows a good accessibility of the tools to the workpiece. Collision-free tool paths and a 5-sided workpiece machining can be achieved with short standard tools.

Due to the good swarf protection, workholding systems HILMA.MCP are particularly suitable for the use in pallet systems.

The high force and stability obviate the need for pre-stamping of the workpieces.

#### Accessories

- Clamping jaws and jaw inserts, accessories for mounting, positioning and operation see data sheet WS 5.450Z
- Rapid change block Quintus see data sheet WS 5.6150

#### Application example



Workholding systems HILMA.MCP in 5-axis arrangement on a 5-axis machining centre.



**Technical data**  
**Dimensions**

**HILMA.MCP 60**

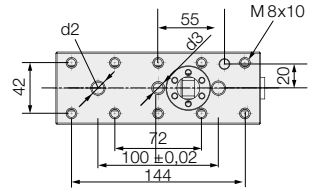
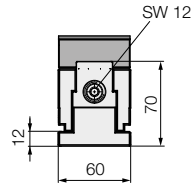
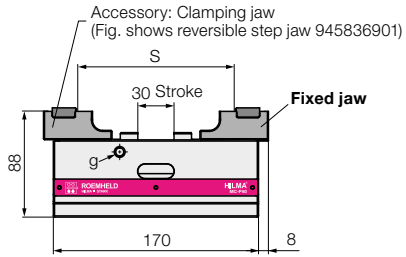

**HILMA.MCP 100**

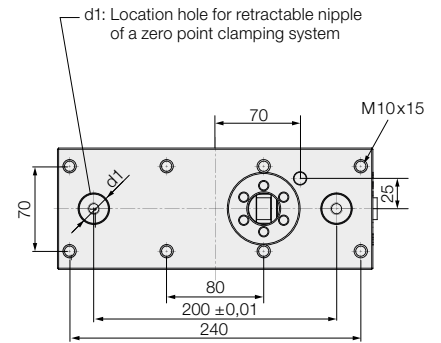
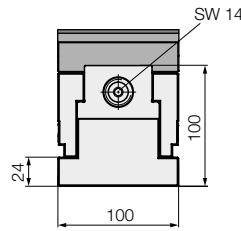
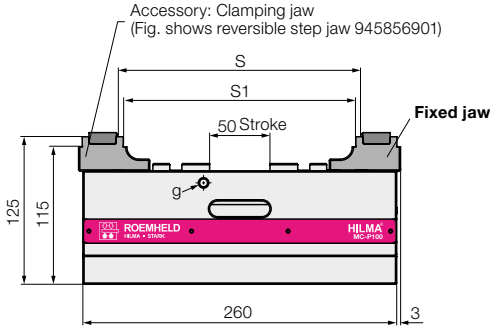

**HILMA.MCP 125 K**

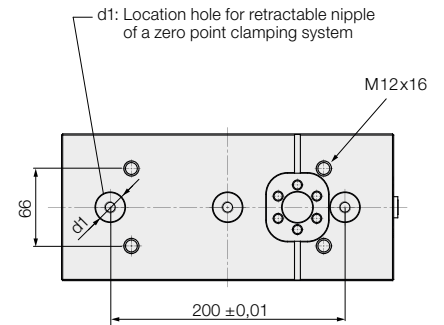
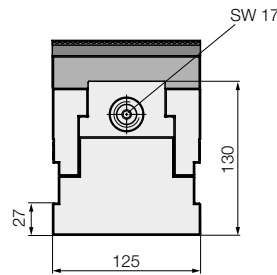
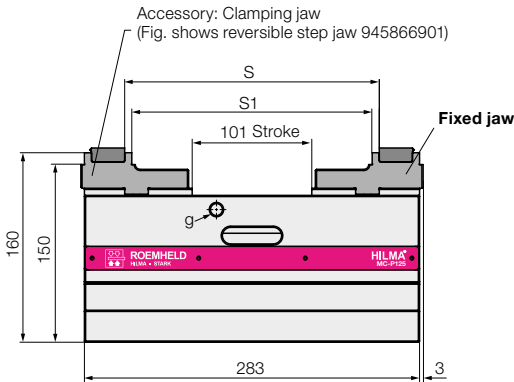

All dimensions in [mm]

Series		HILMA.MCP 60	HILMA.MCP 100	HILMA.MCP 125 K
Clamping principle		Fixed jaw	Fixed jaw	Fixed jaw
Operation		mechanical	mechanical	mechanical
Clamping force / torque	[kN/Nm]	15/60	25/90	40/180
Repetitive clamping accuracy	[mm]	±0.01	±0.01	±0.01
S*	[mm]	6–150	18–204	18–215
S1*	[mm]	–	6–192	6–203
d1	[mm]	–	25+0.01x5 / M10x14	25+0.01x5 / M10x18
d2	[mm]	10F7	–	–
d3	[mm]	M10x11	–	–
g on both sides	[mm]	M8x10	M8x14	M12x18
Weight without clamping jaws	[kg]	4.6	17.5	35.0
Part no. without clamping jaws		945830102	945850102	945860122

\* depending on the used clamping jaw

## Workholding Systems HILMA.MCP Z

### concentric clamping, mechanically or hydraulically operated

#### jaw widths 60, 100 and 125 mm



### Application

The workholding systems HILMA.MCP Z are especially advantageous for 5-axis machining. The compact design allows a good accessibility of the tools to the workpiece. Collision-free tool paths and a 5-sided workpiece machining can be achieved with short standard tools. Due to the good swarf protection, workholding systems HILMA.MCP Z are particularly suitable for the use in pallet systems. The high force and stability obviate the need for pre-stamping of the workpieces.

### Accessories

- Clamping jaws and jaw inserts, accessories for mounting, positioning and operation see data sheet WS 5.450Z
- Rapid change block Quintus see data sheet WS 5.6150
- Hydraulic pressure generators on request

### Application example

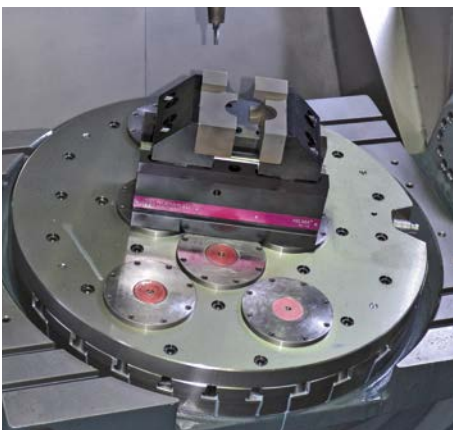

Workholding system HILMA.MCP Z with workpiece-specific base jaw and form jaw used on a 5-axis machining centre.

### Advantages

- Patented segment design
- Compact design
- High precision and accuracy of the manufactured workpieces by high rigidity
- High zero-point stability
- Sturdy design and good swarf protection
- Large jaw openings
- Extensive range of jaws
- Clamping of raw and finished parts without retrofitting
- Easy to maintain

### Description

Workholding systems of the HILMA.MCP Z series excel by a very compact design and their patented segment design. Thanks to the adjusting spindle arranged in the upper part of the housing, deformation in the base during clamping is reduced to a minimum. Thus, a high rigidity of the workholding system is obtained.

The patented segment design ensures a high degree of precision and stability. The guiding clearance is reduced to nearly zero. All essential components are made of hardened steel.

The workholding systems HILMA.MCP 100Z/125Z are already prepared for the use on zero point clamping systems. For this purpose, there are location threads for retractable nipples at the bottom side of the housing.

For workholding systems HILMA.MCP Z, a wide range of clamping jaws is available (see data sheet WS 5.450Z).

### Consultation

Our experts will be pleased to advise you also on site, and work with you to find the optimum clamping solution. Extensive information such as drawings and CAD models are available on request.

### Customised versions

HILMA.MCP workholding systems can also be delivered as customised versions. For example with other lengths, height or with individual mounting holes. Please contact us.

### \*Important note

The specified clamping forces apply to a clamping height (n) of 15 mm. For higher clamping heights, the clamping forces are reduced.

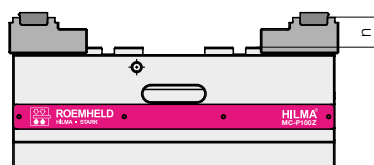

### Technical data

Clamping principle:	<b>concentric clamping</b>
Operation:	<b>mechanically</b> with a torque wrench <b>hydraulically</b> with a power unit

### HILMA.MCP 60 Z and ZH

Jaw width:	60 mm
Mechanical clamping force*:	15 kN at 60 Nm
Hydraulic clamping force*:	10 kN at 320 bar
Clamping stroke:	30 mm
Max. jaw opening:	6–150 mm

### HILMA.MCP 100 Z and ZH

Jaw width:	100 mm
Mechanical clamping force*:	25 kN at 90 Nm
Hydraulic clamping force*:	20 kN at 270 bar
Clamping stroke:	50 mm
Max. jaw opening:	6–204 mm

### HILMA.MCP 125 Z and ZH

Jaw width:	125 mm
Mechanical clamping force*:	40 kN at 180 Nm
Hydraulic clamping force*:	35 kN at 270 bar
Clamping stroke:	101 mm
Max. jaw opening:	6–400 mm

### HILMA.MCP 125 ZK

Jaw width:	125 mm
Clamping force*:	40 kN at 180 Nm
Clamping stroke:	10 kN
Max. jaw opening:	6–215 mm

### Versions

#### HILMA.MCP Z mechanically operated

In the mechanically-operated version, the clamping force is built up with a threaded spindle. When operating, both clamping slides move mechanically linked to the centre of the clamping system. A torque wrench is used for exact and reproducible clamping force adjustment.

#### HILMA.MCP ZH hydraulically operated

In the hydraulically-operated version, the clamping force is built up by an externally generated hydraulic pressure. When pressurising, both clamping slides move mechanically linked to the centre of the clamping system. During unclamping, the clamping slides return hydraulically to the position that had been set with adjusting screws for stroke limitation. Thus, a further unnecessary wide opening of the clamping system is avoided. The clamping force adjustment is made by the setting of the operating pressure.

**Technical data • Dimensions**  
**mechanically operated • jaw widths 60 and 100 mm**

**HILMA.MCP 60 Z**

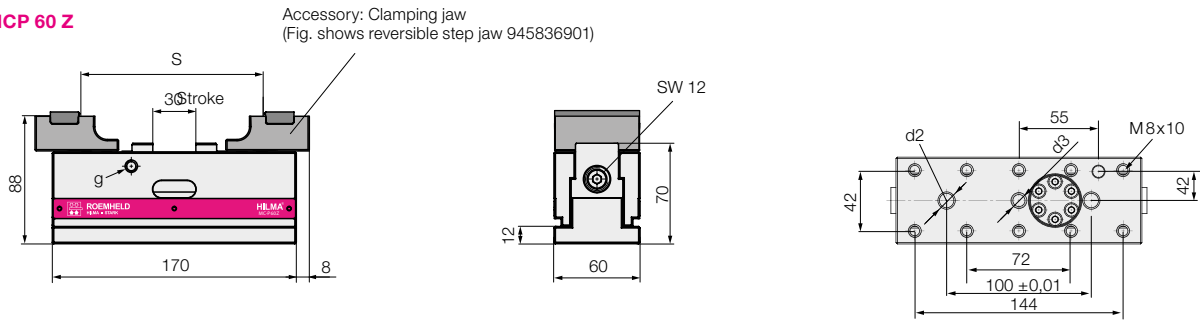

**HILMA.MCP 100 Z**

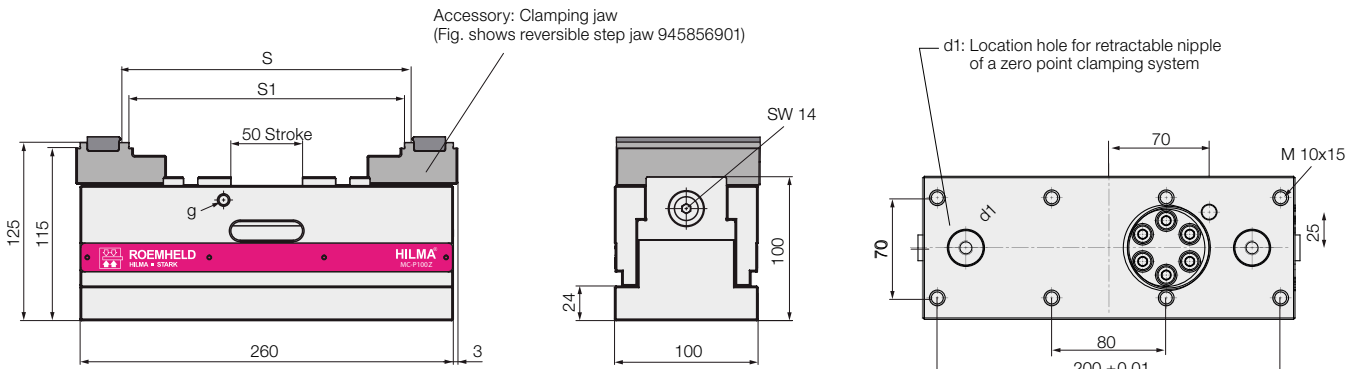

All dimensions in [mm]

Series		HILMA.MCP 60 Z	HILMA.MCP 100 Z
<b>Clamping principle</b>		<b>concentric</b>	<b>concentric</b>
<b>Operation</b>		<b>mechanical</b>	<b>mechanical</b>
<b>Clamping force / torque</b>	[kN/Nm]	15/60	25/90
<b>Repetitive clamping accuracy</b>	[mm]	± 0.015	± 0.015
<b>S*</b>	[mm]	6–150	18–204
<b>S1*</b>	[mm]	–	6–192
<b>d1</b>	[mm]	–	25+0.01x5 / M10x14
<b>d2</b>	[mm]	10F7	–
<b>d3</b>	[mm]	M10x11	–
<b>g on both sides</b>	[mm]	M8x10	M8x14
<b>Weight without clamping jaws</b>	[kg]	4.7	17.7
<b>Part no. without clamping jaws</b>		<b>945830302</b>	<b>945850302</b>

\* depending on the used clamping jaw



**Technical data • Dimensions**  
**mechanically operated • jaw width 125 mm**

**HILMA.MCP 125 Z**

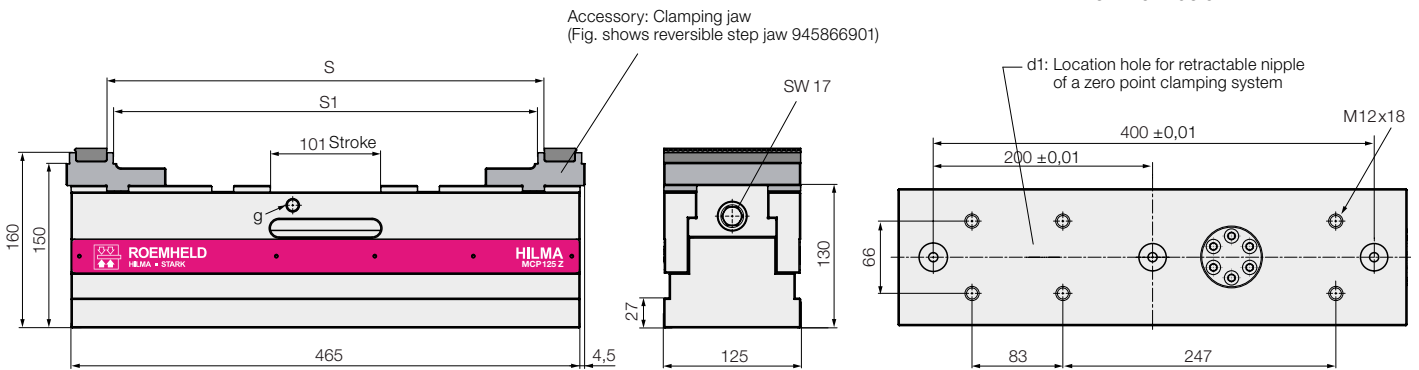

**HILMA.MCP 125 ZK**

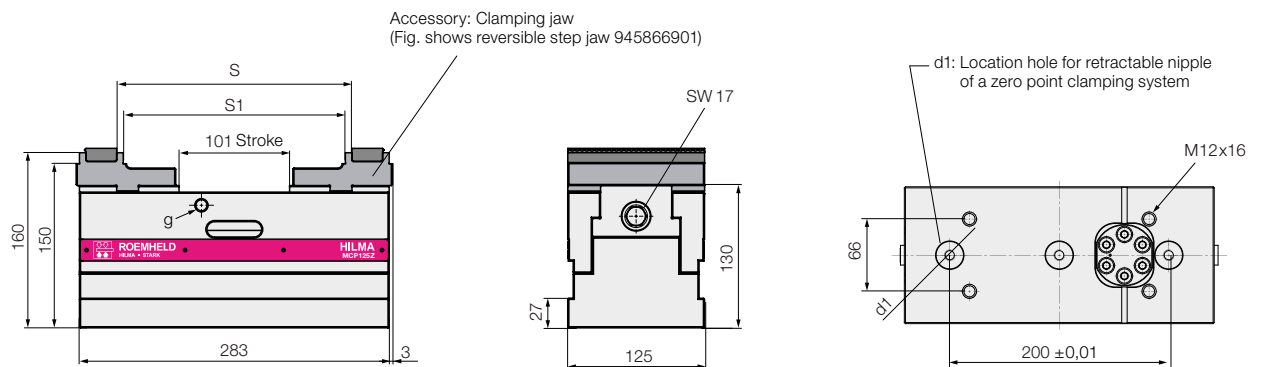

All dimensions in [mm]

Series		HILMA.MCP 125 Z	HILMA.MCP 125 ZK
Clamping principle		concentric	concentric
Operation		mechanical	mechanical
Clamping force / torque	[kN]	40/180	40/180
Repetitive clamping accuracy	[mm]	± 0.015	± 0.015
S*	[mm]	18–400	18–215
S1*	[mm]	6–388	6–203
d1	[mm]	25 + 0.01 x 5 / M10 x 18	25 + 0.01 x 5 / M10 x 18
g on both sides	[mm]	M12 x 18	M12 x 18
Weight without clamping jaws	[kg]	52.3	30.5
Part no. without clamping jaws		945860302	945860322

\* depending on the used clamping jaw

## Technical data • Dimensions

### hydraulically operated • jaw widths 60, 100 and 125 mm

#### HILMA.MCP60 ZH

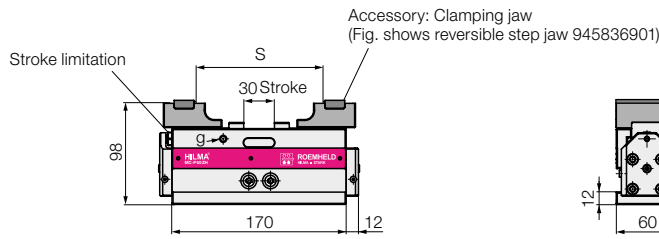

View from below

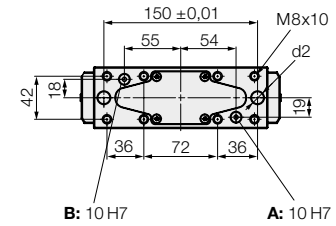

**A:** Clamping  
**B:** Unclamping

#### HILMA.MCP100 ZH

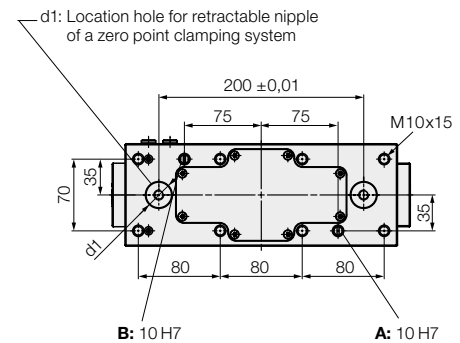
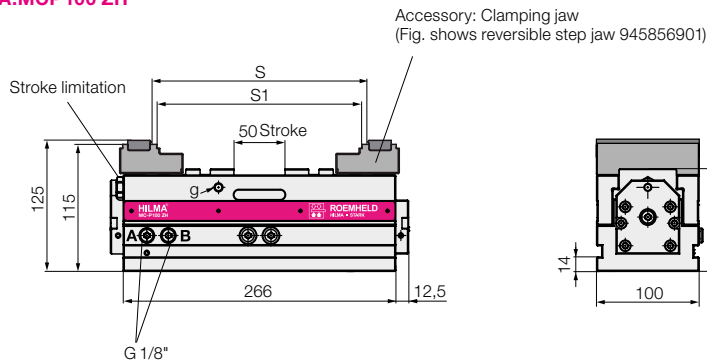

**B:** 10 H7  
**A:** 10 H7

#### HILMA.MCP125 ZH

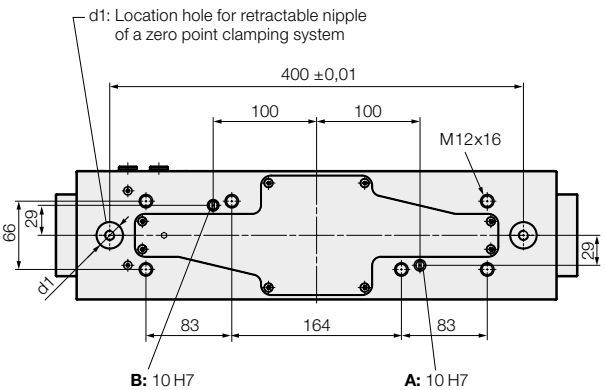
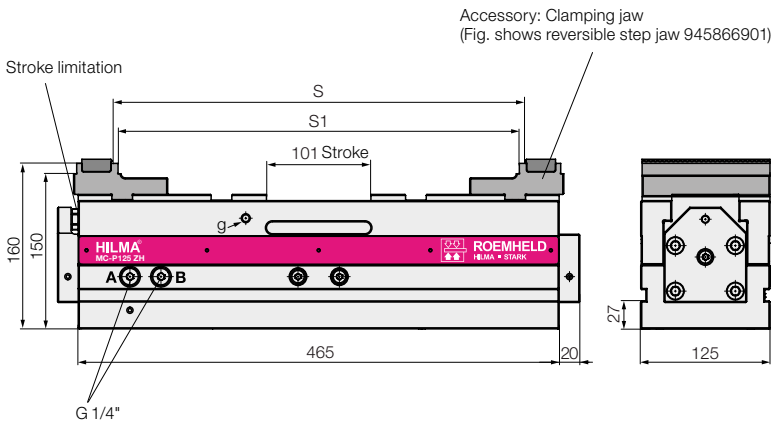

All dimensions in [mm]

Series		HILMA.MCP60 ZH	HILMA.MCP100 ZH	HILMA.MCP125 ZH
Clamping principle		concentric	concentric	concentric
Operation		hydraulic	hydraulic	hydraulic
Clamping force / operating pressure	[kN/bar]	10/320	20/270	35/270
Max. unclamping pressure	[bar]	50	50	50
Max. oil volume	[cm <sup>3</sup> ]	15	51	161
Oil volume per 1 mm stroke	[cm <sup>3</sup> ]	0.5	1	1.6
Repetitive clamping accuracy	[mm]	± 0.02	± 0.02	± 0.02
S*	[mm]	6–150	18–204	18–400
S1*	[mm]	–	6–192	6–388
d1	[mm]	–	25+0.01 x5 / M10x14	25+0.01 x5 / M10x14
d2	[mm]	12F7	–	–
g on both sides	[mm]	M6x7	M8x11	M8x11
Weight without clamping jaws	[kg]	5.4	17.4	50.5
Part no. without clamping jaws		945830401	945850401	945860401

\* depending on the used clamping jaw

## Workholding Systems HILMA.MCP Z Balance position flexible clamping, mechanically operated jaw widths 60, 100 and 125 mm



### Application

Besides 5-axis machining and concentric clamping, the position flexible workholding system HILMA.MCP Balance offers the solution for individual or series clamping of bars, rails, profiles, guide rails or housings. The compensating function avoids tensioning and deformation on the workpiece.

Also workpieces that are fixed by internal contours or positioning elements can be clamped concentrically. For this purpose, customer-specific dowel holes or tapped holes can be provided in the guide bars of the HILMA.MCP Balance in which the workpiece supports or stops can be fixed.

### Accessories

- Clamping jaws and jaw inserts, accessories for mounting, positioning and operation see data sheet WS 5.450Z
- Rapid change block Quintus see data sheet WS 5.6150

### Application example



Clamping of aluminium bars with workholding system HILMA.MCP 100 Z Balance.

### Advantages

- Patented segment design
- Clamping without deformation of workpieces by position flexible clamping point
- Clamping system also suitable for concentric clamping
- Compact design
- High precision and accuracy of the manufactured workpieces by high rigidity
- Sturdy design and good swarf protection
- Large jaw openings
- Extensive range of jaws
- Clamping of raw and finished parts without retrofitting
- Easy to maintain

### Description

Workholding systems of the HILMA.MCP Z Balance series excel by a very compact design and their patented segment design. Due to the position flexible function, deformation of the workpiece during clamping can be avoided.

The patented segment design ensures a high degree of precision and stability. The guiding clearance is reduced to nearly zero.

All essential components are made of hardened steel.

The workholding systems HILMA.MCP 100/125 Z Balance are already prepared for the use on zero point clamping systems. For this purpose, there are location threads for retractable nipples at the bottom side of the housing.

For workholding systems HILMA.MCP Z Balance a wide range of clamping jaws is available (see data sheet WS 5.450Z).

### Customised versions

HILMA.MCP Z Balance workholding systems can also be delivered as customised versions. For example with other lengths or with individual mounting holes. Please contact us.

### Consultation

Our experts will be pleased to advise you also on site, and work with you to find the optimum clamping solution.

Extensive information such as drawings and CAD models are available on request.

### Technical data

Clamping principle:	<b>position flexible</b>
Operation:	<b>mechanically</b> with a torque wrench
Compensation stroke:	± 2 mm

#### HILMA.MCP 60 ZB

Jaw width:	60 mm
Clamping force*:	15 kN at 60 Nm
Clamping stroke:	30 mm
Max. jaw opening:	6 – 150 mm

#### HILMA.MCP 100 ZB

Jaw width:	100 mm
Clamping force*:	25 kN at 90 Nm
Clamping stroke:	50 mm
Max. jaw opening:	6 – 204 mm

#### HILMA.MCP 125 ZB

Jaw width:	125 mm
Clamping force*:	40 kN at 180 Nm
Clamping stroke:	101 mm
Max. jaw opening:	6 – 400 mm

### Function

The workholding systems HILMA.MCP Z Balance have a floating clamping point (with released locking). After operation of the clamping spindle, first the two clamping slides concentrically approach a location-fixed workpiece position. When both clamping jaws are in contact with the workpiece, the desired clamping force is applied by means of a torque wrench. Until this moment the clamping point is still floating. If the desired clamping force is reached, the clamping point which was floating up to this moment will be safely fixed by the locking spindle.

The adaptation of the clamping point to the location-fixed workpiece position will prevent a deformation of the workpiece

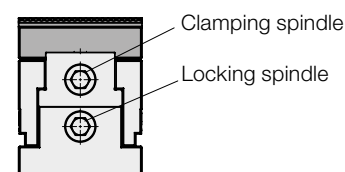

### \*Important note

The specified clamping forces apply to a clamping height (n) of 15 mm. For higher clamping heights, the clamping forces are reduced.

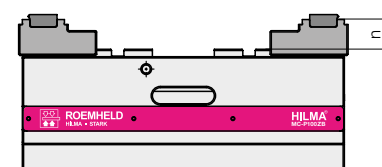

## Technical data

### Dimensions

#### HILMA.MCP 60 ZB

Accessory: Clamping jaw  
 (Fig. shows reversible step jaw 945836901)

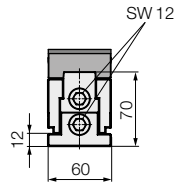
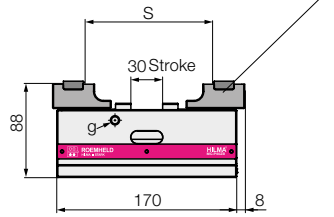

View from below

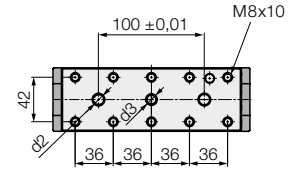

#### HILMA.MCP 100 ZB

Accessory: Clamping jaw  
 (Fig. shows reversible step jaw 945856901)

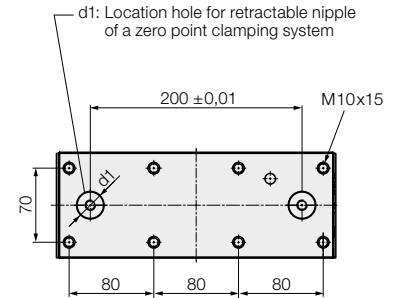
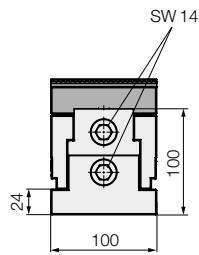
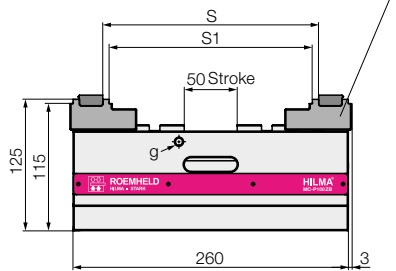

#### HILMA.MCP 125 ZB

Accessory: Clamping jaw  
 (Fig. shows reversible step jaw 945866901)

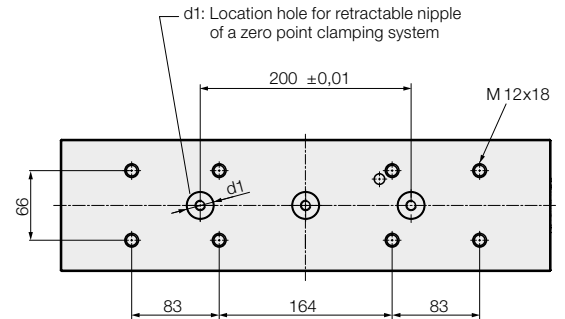
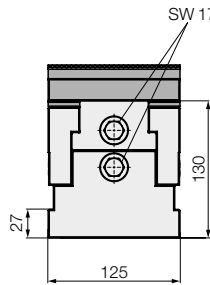
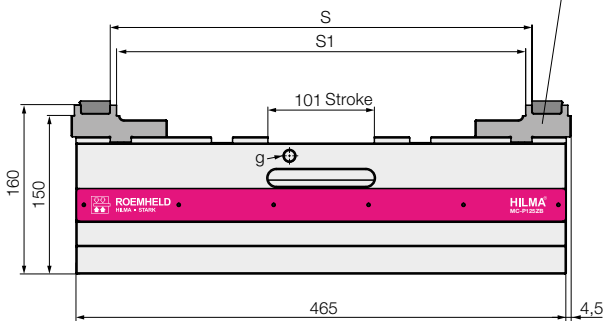

All dimensions in [mm]

Series		HILMA.MCP 60 ZB	HILMA.MCP 100 ZB	HILMA.MCP 125 ZB
Clamping principle		position flexible	position flexible	position flexible
Operation		mechanical	mechanical	mechanical
Clamping force / torque	[kN/Nm]	15/60	25/90	40/180
Repetitive clamping accuracy**	[mm]	± 0.015	± 0.015	± 0.015
Stroke, position flexible	[mm]	± 2	± 2	± 2
S*	[mm]	6–150	18–204	18–400
S1*	[mm]	–	6–192	6–388
d1	[mm]	–	25+0.01 x 5 / M10x14	25+0.01 x 5 / M10x18
d2	[mm]	10F7	–	–
d3	[mm]	M10x11	–	–
g on both sides	[mm]	M8x10	M8x14	M12x18
Weight without clamping jaws	[kg]	4.6	17.5	52.3
Part no. without clamping jaws		945830702	945850702	945860702

\* depending on the used clamping jaw

\*\* with closed locking

## Accessories for Workholding Systems HILMA.MCP Clamping jaws and jaw inserts, accessories for mounting, positioning and operation

### Clamping jaws / jaw inserts



#### Scope of delivery - clamping jaws

All clamping jaws are supplied with fixing screws.  
Reversible step jaws are always delivered without jaw inserts.  
They are to be ordered separately as accessories (see page 3).

#### Important notes

- By the use of clamping jaws with grip jaw inserts, the jaw opening is reduced by approx. 4 mm.
- Technical information and application recommendations for jaw inserts see page 3
- All HILMA.MCP workholding systems are delivered without clamping jaws.
  1. Selection: clamping jaws
  2. Selection: jaw inserts (see page 3)
- Reversible step jaws for jaw inserts can only be used in combination with the appropriate jaw inserts.

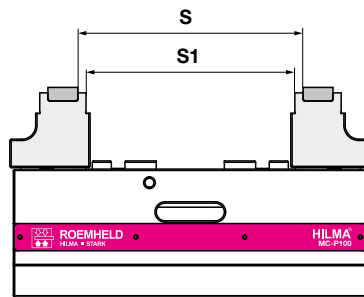
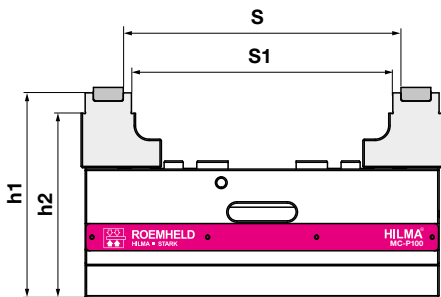

**S:** Clamping range  
step at the jaw insert  
**S1:** Clamping range  
step at the jaw body

**h1:** Height of support  
step at the jaw insert  
**h2:** Height of support  
step at the reversible step jaw

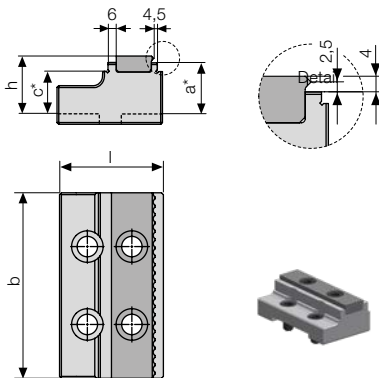

#### Reversible step jaws, flat for 1 jaw insert hardened and ground

Type	Part no.	l	Dimensions				Clamping range		Height of support	
			b	h	a	c	S	S1	h1	h2
<b>MCP 60</b>	<b>945836901</b>	56	60	22	18	-	12-126	-	88	-
<b>MCP 60 ZH</b>	<b>945836901</b>	56	60	22	18	-	12-126	-	98	-
<b>MCP 100</b>	<b>945856901</b>	59	100	29	25	15	18-204	6-192	125	115
<b>MCP 125</b>	<b>945866901</b>	91	125	34	30	20	18-400	6-388	160	150
<b>MCP 125 Compact</b>	<b>945866901</b>	91	125	34	30	20	18-215	6-203	160	150

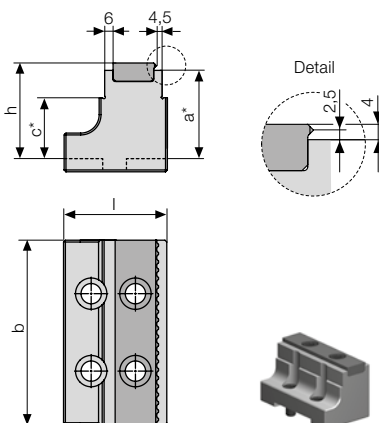

#### Reversible step jaws for 1 jaw insert hardened and ground

Type	Part no.	l	Dimensions				Clamping range		Height of support	
			b	h	a	c	S	S1	h1	h2
<b>MCP 60</b>	<b>945836902</b>	56	60	34	30	-	12-126	-	100	-
<b>MCP 60 ZH</b>	<b>945836902</b>	56	60	34	30	-	12-126	-	110	-
<b>MCP 100</b>	<b>945856902</b>	59	100	54	50	35	18-204	6-192	150	135
<b>MCP 125</b>	<b>945866902</b>	91	125	66	62	42	18-400	6-388	192	172
<b>MCP 125 Compact</b>	<b>945866902</b>	91	125	66	62	42	18-215	6-203	192	172

\* Tolerance ±0.01 mm  
All dimensions in [mm]

## Accessories

### Clamping jaws

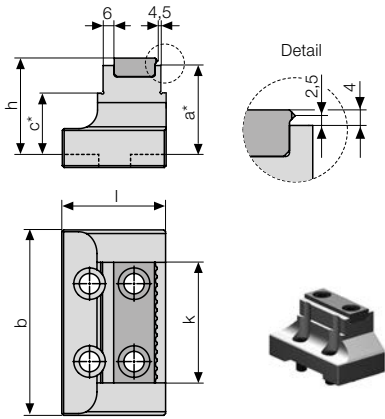

#### Reversible step jaws for 1 jaw insert hardened and ground, various widths

Type	Part no.	Dimensions						Clamping range		Height of support	
		l	b	h	a	c	k	S	S1	h1	h2
<b>MCP 60</b>	<b>945836903</b>	56	60	34	30	-	35	12-126	-	100	-
<b>MCP 60 ZH</b>	<b>945836903</b>	56	60	34	30	-	35	12-126	-	110	-
<b>MCP 100</b>	<b>945856903</b>	59	100	54	50	35	65	18-204	6-192	150	135
<b>MCP 125</b>	<b>945866903</b>	91	125	66	62	42	80	18-400	6-388	192	172
<b>MCP 125 Compact</b>	<b>945866903</b>	91	125	66	62	42	80	18-215	6-203	192	172

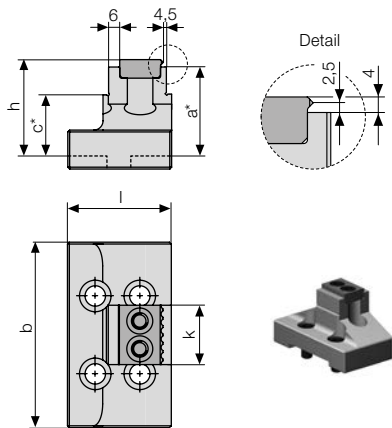

#### Reversible step jaw for 1 jaw insert hardened and ground, various widths

Type	Part no.	Dimensions						Clamping range		Height of support	
		l	b	h	a	c	k	S	S1	h1	h2
<b>MCP 100</b>	<b>945856904</b>	59	100	54	50	35	32	18-204	6-192	150	135

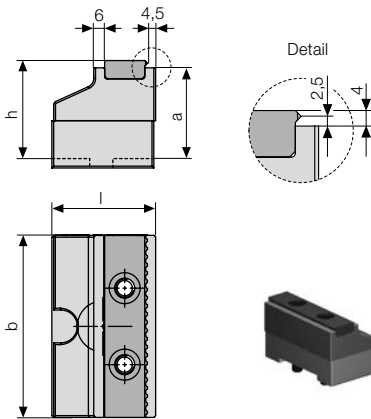

#### Pendulum jaws for 1 jaw insert hardened and ground

Type	Part no.	Dimensions				Clamping range S	Height of support h1
		l	b	h	a		
<b>MCP 100</b>	<b>945856905</b>	56	100	54	50	12-204	150
<b>MCP 125</b>	<b>945866905</b>	88	125	66	62	12-400	192
<b>MCP 125 Compact</b>	<b>945866905</b>	88	125	66	62	12-215	192

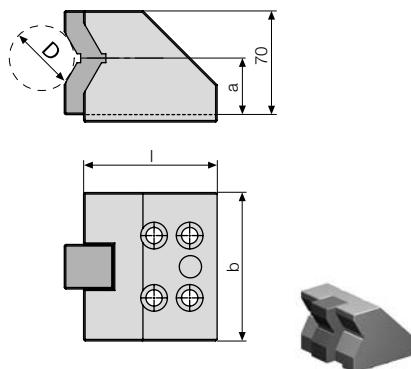

#### Vee jaws with horizontal prism with interchangeable insert, hardened

Type	Part no.	Dimensions			Clamping range D	Clamping centre h1
		l	b	a		
<b>MCP 60</b>	<b>945836921</b>	60	60	40	D 10-76	110
<b>MCP 60 ZH</b>	<b>945836921</b>	60	60	40	D 10-76	120
<b>MCP 100</b>	<b>945856921</b>	90	100	38	D 12-80	138

#### Vee jaws with vertical prism on request

\* Tolerance ±0.01 mm  
All dimensions in [mm]



## Accessories

### Clamping jaws / jaw inserts

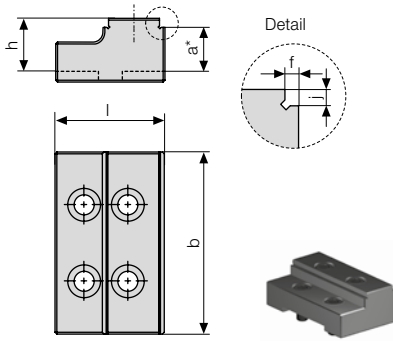

#### Reversible jaws with step hardened

Type	Part no.	Dimensions						Clamping range S	Height of support h1
		l	b	h	a	f	j		
<b>MCP 60</b>	<b>945836931</b>	49	60	23	18	3	5	6-150	88
<b>MCP 60 ZH</b>	<b>945836931</b>	49	60	23	18	3	5	6-150	98
<b>MCP 100</b>	<b>945856931</b>	60	100	30	25	3	5	6-204	125
<b>MCP 125</b>	<b>945866931</b>	80	125	35	30	5	5	6-400	160
<b>MCP 125 Compact</b>	<b>945866931</b>	80	125	35	30	5	5	6-215	160

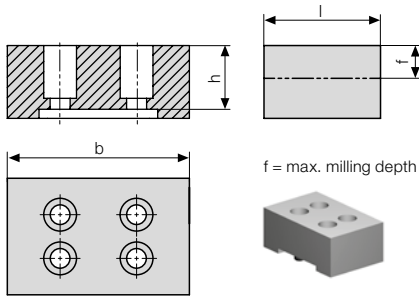

#### Block jaws, soft for milling workpiece contours

Type	Part no.	l	Dimensions b	h	f
<b>MCP 60</b>	<b>945836932</b>	42	60	25	8
<b>MCP 100</b>	<b>945856932</b>	64	100	35	18
<b>MCP 125</b>	<b>945866932</b>	88	125	55	32
<b>MCP 125 Compact</b>	<b>945866932</b>	88	125	55	32

\* Tolerance ±0.01 mm  
All dimensions in [mm]

## Interchangeable jaw inserts

see also: data sheet WS 12-SE Technical information "Jaw inserts for clamping jaws"

#### Jaw inserts grip serrated



**Grip/smooth**

#### Jaw inserts with coatings

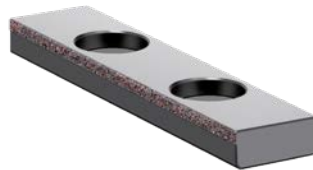

**Grip round**

**Hard metal coarse/smooth**  
Hardness 58 HRC  
Grain size 0.3 – 0.5 mm



**TUC/smooth**  
Hardness 80 HRC  
Coarseness RA 10

#### Recommendation for jaw inserts to increase the retention forces

Workpiece material	Workpiece surface	Workpiece surface				
		rolled / cast / forged	drawn	sawn	milled	ground
Steel, e.g. C45, 20MnCr5, 31CrMoV9		HM coarse, Grip	TUC	HM coarse, Grip	TUC	TUC
Heat-treated steel e.g. C45 induction-hardened, 20 Mn Cr 5 case-hardened, 31 Cr Mo V9 nitrided					TUC	TUC
Cast e.g. GG, red bronze		HM coarse, Grip			TUC	TUC
Titanium			TUC		TUC	TUC
Aluminium		HM coarse, Grip		Grip		TUC
Non-ferrous metals				Grip		TUC

#### Part numbers

Type	Part no.	Part no.	Part no.
<b>MCP 60</b>	<b>Jaw width 60</b>	<b>Jaw width 35</b>	
Jaw inserts Grip/smooth	550500543	550500545	
Jaw inserts HM coarse/smooth	550500635	550500740	
Jaw inserts TUC/smooth	550500743	550500744	
<b>MCP 100</b>	<b>Jaw width 100</b>	<b>Jaw width 65</b>	<b>Jaw width 32</b>
Jaw inserts Grip/smooth	550500542	550500471	550500470
Jaw inserts HM coarse/smooth	550500523	550500723	550500741
Jaw inserts TUC/smooth	550500586	550500745	550500746
Jaw inserts Grip round with fixing screw	932856001		
<b>MCP 125</b>	<b>Jaw width 125</b>	<b>Jaw width 80</b>	
Jaw inserts Grip/smooth	550500509	550500547	
Jaw inserts HM coarse/smooth	550500660	550500742	
Jaw inserts TUC/smooth	550500747	550500748	
Jaw inserts Grip round with fixing screw	932856003		

## Mounting and positioning

### Centring bolts for hub centring on machine table



Type	Part no.	Ø [mm]	L [mm]
Quintus 1/2/3	961535001	D30 g6	15/38
	961535002	D32 g6	15/38
	961535003	D50 g6	25/48
	961535009	D50 g6	18/41

### Retractable nipples for mounting at the clamping system



Type	Part no.	Quantity
Quintus 1 / MCP 60	939200201	1 off
Quintus 2 / MCP 100	939200202	1 set = 2 off
Quintus 3 / MCP 125	939200203	1 set = 3 off

### Positioning pins stepped for grid plate, set of 2 off



Type	Part no.	Ø [mm]
MCP 60	939200101	10/12
MCP 100 / MCP 125	939200103	25/12

### Clamping claws if 1 set = 4 off, incl. screws

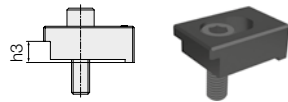

Type	Part no.	Thread	h3 [mm]
MCP 60	937772031	M10	12
MCP 60	937772041	M12	12
MCP 100	937772011	M12	24
MCP 100 ZH	937772061	M12	14
MCP 125	937773011	M12	27
MCP 125	937773021	M16	27

### Key block



Part no.	Slot [mm]
961535004	DIN 6322, 1 off

### T-nut with screw for Quintus 1,2,3



Part no.	Slot [mm]
961535005	DIN 508, 4 off

## Operation

### Torque wrenches



Type	Part no.	Torque [Nm]
MCP 60	937926600	5 – 60
MCP 100	937926610	20–120
MCP 125	937926620	40–200

### Sockets for torque wrenches



Type	Part no.	SW
MCP 60	131240021	12
MCP 100	131240020	14
MCP 125	131240017	17

### Allen wrenches for fixing screws and jaw inserts



Type	Part no.	SW
MCP 60	169110002	6
MCP 100	169110003	8
MCP 125	169110005	10

### T-nuts DIN 508, 1 set = 4 off

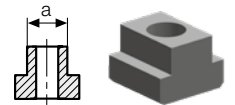

Type	Part no.	Thread	Width a
MCP 60	937773002	M10	12
MCP 60	937773003	M10	14
MCP 60/MCP 100	937773004	M12	18
MCP 125	937773231	M12	18
MCP 125	937773311	M16	18

## Hydraulic connection

### Plug-in connector for hydraulic connection from below including seals, 1 off

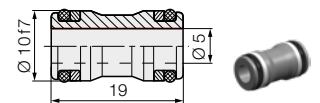

Part no.	for bore hole
805300023	Ø 10 H7 x 10 mm deep





## More Information.

You want to know more about our products & services?  
Please visit our websites.

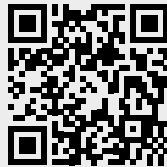

STARK Spansysteme GmbH  
[www.stark-roemheld.com](http://www.stark-roemheld.com)



ROEMHELD Group  
[www.roemheld.de](http://www.roemheld.de)

In the download center you will find among others

- ▶ Brochures
- ▶ Catalogs
- ▶ Operating instructions
- ▶ Functional videos



HILMA MACHINE VICES CAN BE PERFECTLY COMPLEMENTED AND COMBINED WITH STARK ZERO POINT CLAMPING SYSTEMS.

## USE SYNERGIES



- ▶ HILMA.ASH automated workholding system on zero point clamping system
- ▶ Fast closing plate with 4 elements STARK.classicNG.2 Twister and media duct for clamping/releasing the vice
- ▶ Coupling unit with zero-point clamping system (device pallet - handling system) 2 elements STARK.airtec with integrated querye



A COMPANY OF THE  
ROEMHELD GROUP

## STARK Spannsysteme

The ROEMHELD Group consists of 5 companies at locations in Germany and Austria, each with different products and orientations. With numerous subsidiaries, sales partners and service companies on all continents and in more than 50 countries, rapid and intensive customer support is provided in the mechanical engineering, medical technology, automotive, aviation and agricultural industries.

As part of the ROEMHELD Group, STARK benefits from the security and experience of a family-run traditional company as well as from the worldwide sales and service network. At the same time, this background provides the independence to pursue dynamic and innovative goals for new market-driven developments and customer-specific solutions with which STARK maintains its leading technological position.



**ROEMHELD**  
HILMA ■ STARK

## **STARK** Spannsysteme

A company of the ROEMHELD Group

STARK Spannsysteme GmbH  
Römergrund 14 | 6830 Rankweil  
Austria

+43 5522 37 400 - 0  
info@stark-roemheld.com

[stark-roemheld.com](http://stark-roemheld.com)