

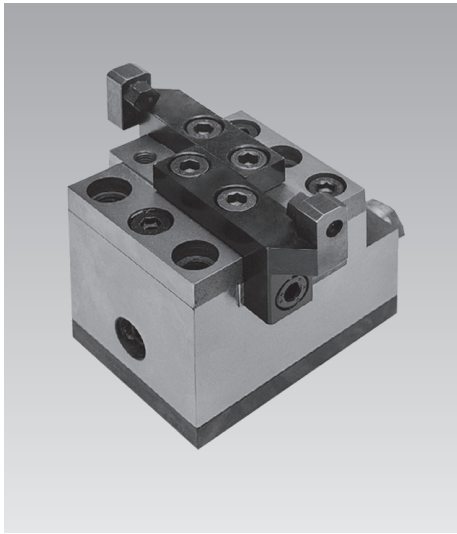

## Parallel Slide Centring Elements

### double acting, max. operating pressure 500 bar



#### Advantages

- High force density in a very compact design
- Centering repeatability 0.02 mm
- Sturdy and proven mechanics
- Retaining force 3 times greater than clamping force
- Suitable for interior or exterior clamping
- Flange and pipe connection as standard
- Connection for positive air pressure protection as standard
- Connection for central lubrication as standard

#### Application

This element is used in clamping fixtures in order to centre workpieces with narrow complicated contours and ribbing serving as a base for the definition of tolerances.

#### Description

Thanks to the clever arrangement of the centre of rotation relative to the hydraulic piston, the retaining force of a clamping jaw is three times higher than the clamping force. If only one clamping jaw acts at the workpiece, the clamping force is twice as high. This happens as long as the workpiece is moved to the centre.

#### Clamping jaws

The clamping jaws, to be manufactured by the customer according to the special application, are precisely positioned at the clamping slide by means of a centre pin and a lateral key. The clamping jaws are fixed from above by means of three screws and from the side by one screw. The above figure shows a parallel slide centring element with clamping jaws and contact bolts. The clamping process is effected from the outside to the inside (exterior clamping).

#### Schematic diagram

Double-acting parallel slide centering element

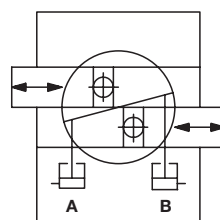

#### Important note

The element is filled with 20% grease (3.5 cm<sup>3</sup>) when delivered.

#### Recommendations for Lubrication

The element has a lubricating nipple for manual lubrication and three connecting holes on the flange side. These can be used either as lubrication connections or alternatively for air sealing. All lubrication points are connected.

If one of the connections is operated with sealing air, it must be water-free and oiled, and pressure must not exceed 0.5 bar.

Both Klüber Alttemp Q NB 50 as well as slide way oil (e.g. Mobile Vactra 2 to 4) in accordance with ISO VG 68 for automatic lubrication and in accordance with ISO VG 220 for manual lubrication can be used as lubricants.

The lubrication intervals and lubrication quantities must be defined by the operator, as they depend greatly on application conditions.

For applications without coolant penetration, the lubrication interval can be increased to up to 20,000 cycles. For applications with cooling lubricant penetration, lubrication must be adjusted at short intervals and in small quantities.

# Technical Characteristics Dimensions

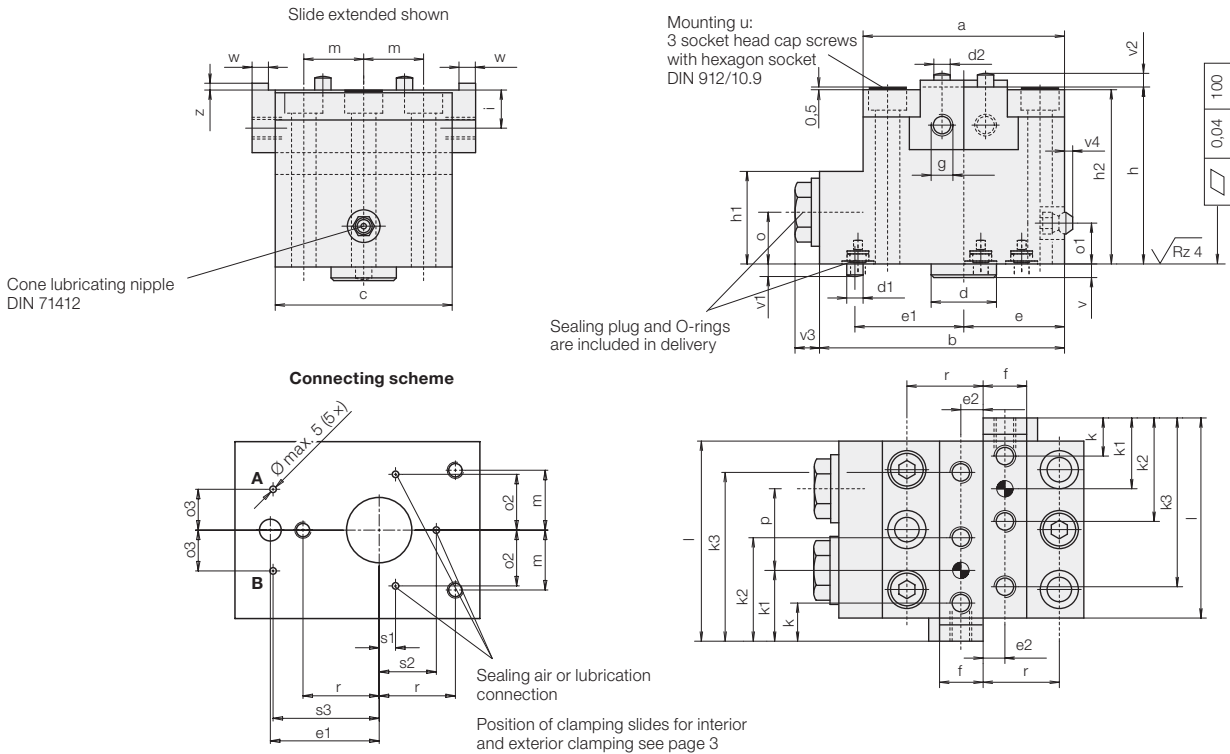

Shortest clamping time: 0.5 s  
Centering repeatability  $\pm 0.02$  mm

Max. flow rate	[cm <sup>3</sup> /s]	0.32	0.6	1.0
Clamping force/jaw $F_{Sp}$ at y	[kN]	2.8	5.0	8.8
Stroke / jaw	[mm]	6	7	8
Piston $\varnothing$	[mm]	12	16	20
a	[mm]	62	74	90
b	[mm]	82	90	105
c	[mm]	55	65	75
d h6	[mm]	22	24	26
d1 m6	[mm]	6	8	8
d2 m6	[mm]	6	6	8
e	[mm]	31	37	45
e1 $\pm 0.02$	[mm]	40	40	50
e2 $\pm 0.1$	[mm]	7	9	11
f	[mm]	13	16	20
g	[mm]	M 6 $\times$ 10	M 8 $\times$ 11	M 10 $\times$ 13
h	[mm]	56	65	76
h1	[mm]	31	34	42
h2	[mm]	55	64	75
i	[mm]	12	14	17
k	[mm]	12	14	17
k1 $\pm 0.02$	[mm]	22	26	31
k2	[mm]	32	38	45
k3	[mm]	52	62	73
l	[mm]	62.5	73.5	85
m	[mm]	20	22	27
o	[mm]	16	19	21
o1	[mm]	13	15	15
o2	[mm]	17.5	20.5	25
o3	[mm]	13	15	18.5
r	[mm]	23	28	34
s1	[mm]	6	6	7
s2	[mm]	17.5	21	25.5
s3	[mm]	37	39	46
u 3x	[mm]	M 6 $\times$ 60	M 8 $\times$ 70	M 10 $\times$ 80
v	[mm]	4	5	6
v1	[mm]	5	6	6
v2	[mm]	5	5	6
v3	[mm]	9	9	7
v4	[mm]	3	0	0
w j7	[mm]	5	6	8
z	[mm]	2.2	2.5	3
Weight	[kg]	1.7	2.7	4.4
Oil volume per mm clamping slide stroke	[cm <sup>3</sup> ]	0.16	0.28	0.47
<b>Part no.</b>		<b>4316120</b>	<b>4316160</b>	<b>4316200</b>

**Exterior clamping**  
A = Clamping / B = Unclamping

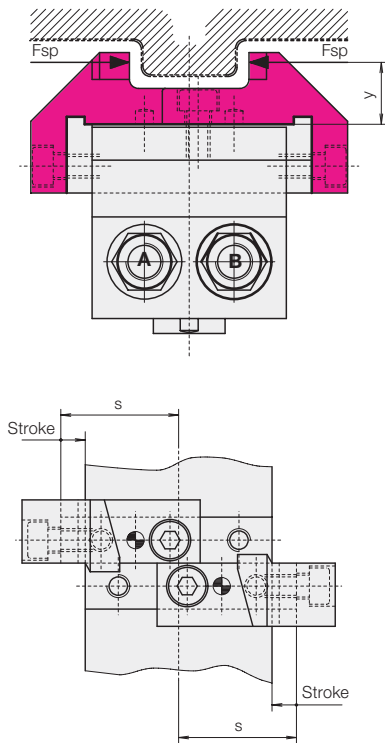

**Interior clamping**  
A = Unclamping / B = Clamping

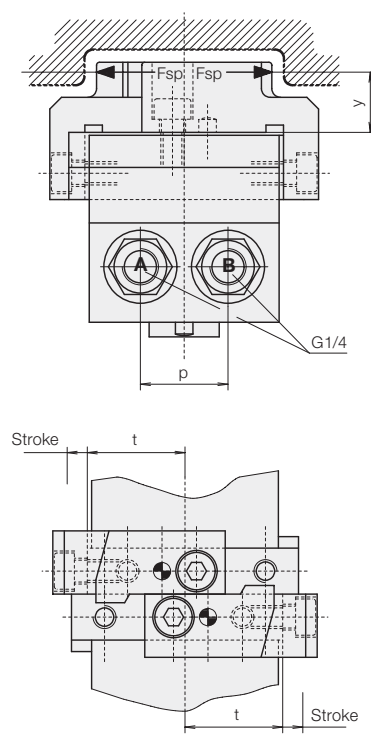

**Example of clamping jaw**  
(to be manufactured by the customer)

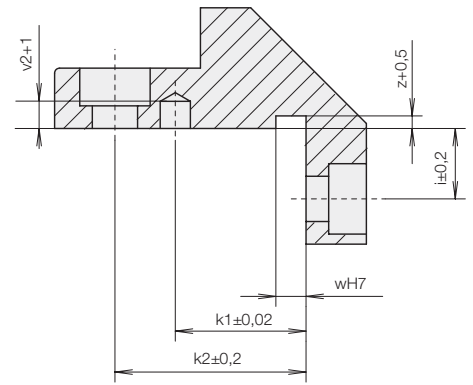

p	[mm]	26	30	37
s	[mm]	35	41	47,5
t	[mm]	29	34	39,5
y applic. of force	[mm]	20	24	28

**Hint**

In case of 2 x y the clamping force will be reduced by 6% (friction loss).

**Application example**

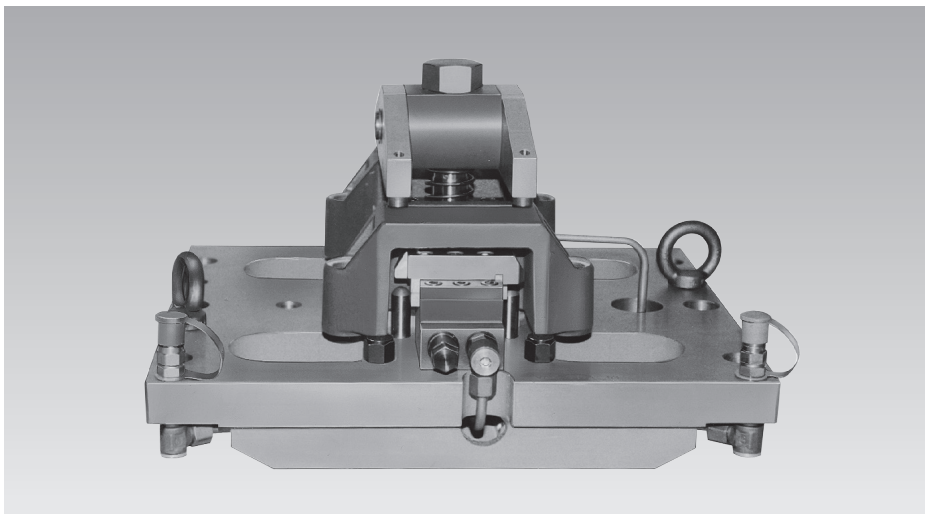

The opposite figure shows a hydraulically-operated fixture for concentric positioning and clamping of two casted housings, whose interior surfaces are due to functional reasons have to be concentrically arranged to the machined holes.

The machining of the interior surfaces could be avoided thanks to the use of concentric clamping elements.

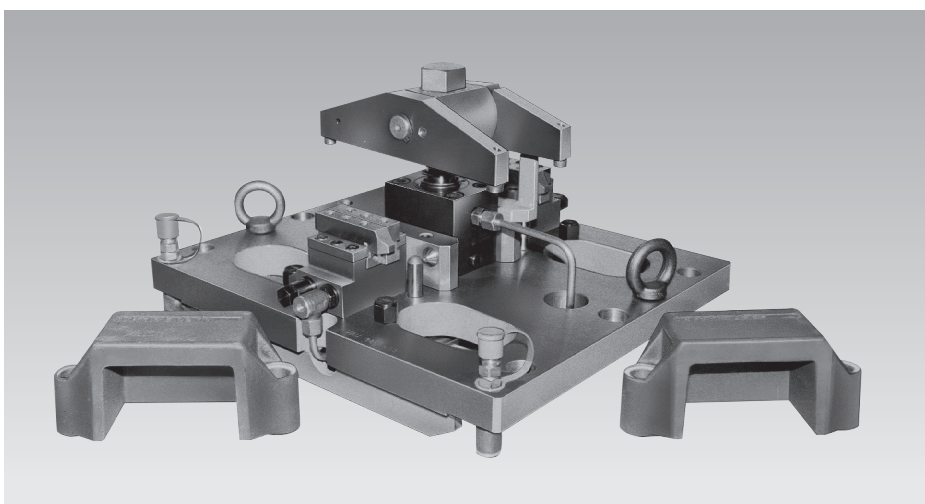

The clamping fixture in plate constructions installed on a vertical machining centre with rotary indexing table and trunnion bearing.