



ROEMHELD
HILMA ■ STARK



HILMA.MCP

Compact 5-axis clamping system

Jaw width 60 - 125 mm

WS 5.4501, WS 5.4502, WS 5.4503, WS 5.450Z



ROEMHELD
HILMA ■ STARK

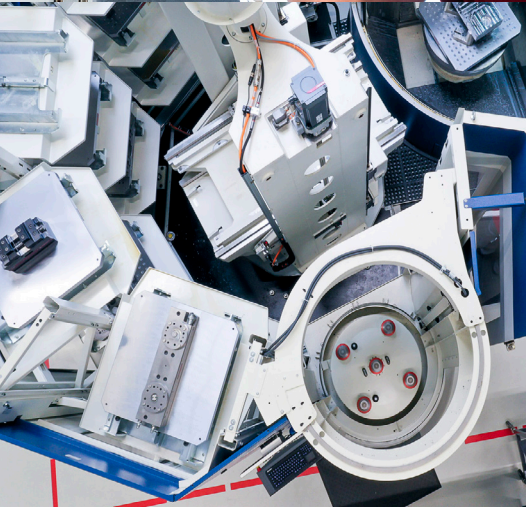
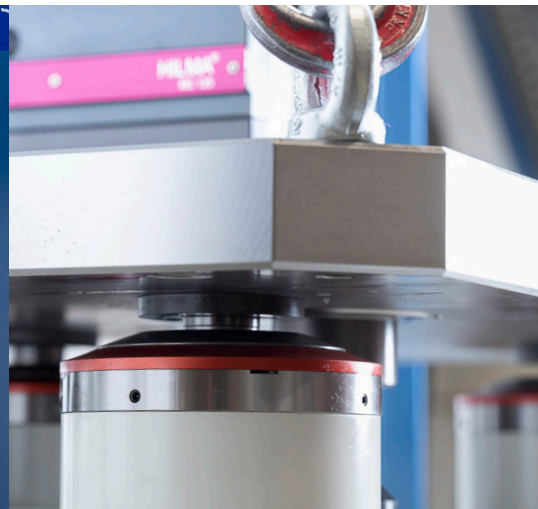

STARK INNOVATIVE PROFICIENT INDIVIDUAL SAFE

The high-tech company STARK Spannsysteme was established in 1977 in Rankweil, Austria. It manufactures zero point clamping systems and vices of the highest quality and precision for international clients in the automotive, aviation and medical industries, for example.

STARK Spannsysteme products are a byword for minimal set-up times, faster production and high flexibility.

HILMA vices can be complemented and combined perfectly with STARK zero point clamping systems.

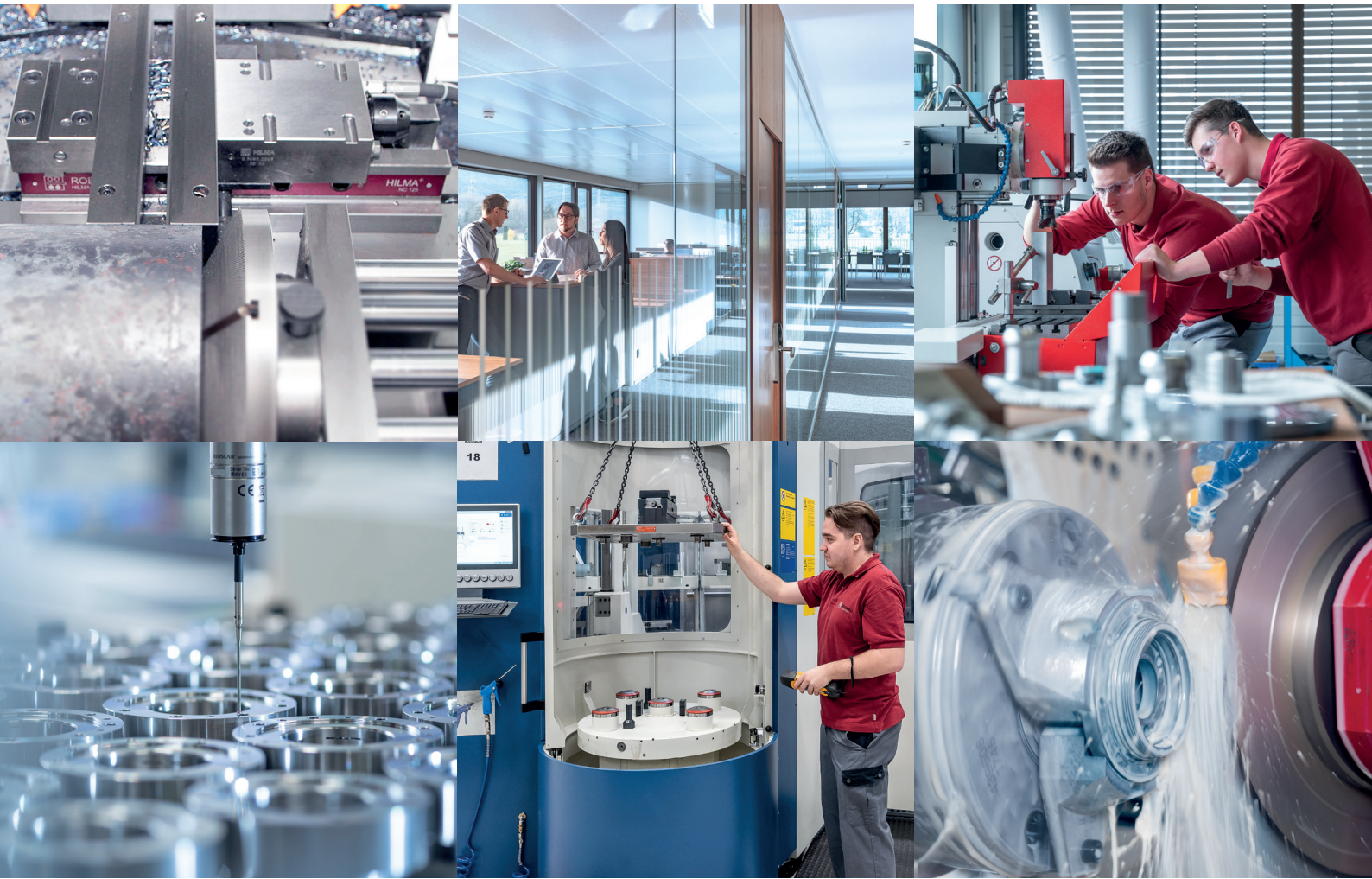

AUTOMOTIVE



AVIATION



MACHINE AND TOOL
CONSTRUCTION



MEDICINE

FOCUS ON INDUSTRIES & MARKETS.

Every customer has specific requirements. Our established and extensive industry expertise allows us to offer you the best solutions, services and products for sustainable and efficient use in your market.

HILMA.MCP



HILMA.MCP



HILMA.UC



HILMA.SCS

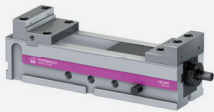

HILMA.KNC



HILMA.NC

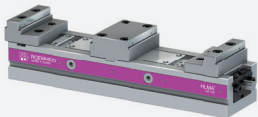

HILMA.DS

5-AXIS MACHINING

VERTICAL MACHINING

HORIZONTAL MACHINING

AUTOMATION

HILMA

Workpiece clamping systems

More productivity through:

- maximum flexibility in production
- highest process reliability
- reduced manufacturing costs through set-up time optimisation



HILMA.SCT



HILMA.TS Vector



HILMA.TS TriStar



HILMA.ASE



HILMA.ASH

WS 5.4501 Workholding Systems HILMA.MCP

clamping against the fixed jaw, mechanically operated

jaw widths 60, 100 and 125 mm



Advantages

- Patented segment design
- Compact design
- High precision and accuracy of the manufactured workpieces by high rigidity
- High zero-point stability
- Sturdy design and good swarf protection
- Large jaw openings
- Extensive range of jaws
- Clamping of raw and finished parts without retrofitting
- Easy to maintain

Technical data

Clamping principle: **clamping against the fixed jaw mechanically**
 Operation: with a torque wrench

HILMA.MCP 60

Jaw width: 60 mm
 Clamping force*: 15 kN at 60 Nm
 Clamping stroke: 30 mm
 Max. jaw opening: 6–150 mm

HILMA.MCP 100

Jaw width: 100 mm
 Clamping force*: 25 kN at 90 Nm
 Clamping stroke: 50 mm
 Max. jaw opening: 6–204 mm

HILMA.MCP 125 K

Jaw width: 125 mm
 Clamping force*: 40 kN at 180 Nm
 Clamping stroke: 101 mm
 Max. jaw opening: 6–215 mm

Application

The workholding systems HILMA.MCP are especially advantageous for 5-axis machining. The compact design allows a good accessibility of the tools to the workpiece. Collision-free tool paths and a 5-sided workpiece machining can be achieved with short standard tools. Due to the good swarf protection, workholding systems HILMA.MCP are particularly suitable for the use in pallet systems. The high force and stability obviate the need for pre-stamping of the workpieces.

Accessories

- Clamping jaws and jaw inserts, accessories for mounting, positioning and operation see data sheet WS 5.450Z
- Rapid change block Quintus see data sheet WS 5.6150

Application example

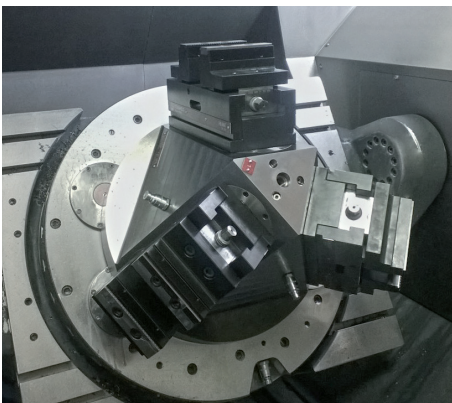

3 workholding systems HILMA.MCP in 3x120°-arrangement on a 5-axis machining centre.

Description

Workholding systems of the HILMA.MCP series excel by a very compact design and their patented segment design.

Thanks to the adjusting spindle arranged in the upper part of the housing, deformation in the base during clamping is reduced to a minimum. Thus, a high rigidity of the workholding system is obtained.

The patented segment design ensures a high degree of precision and stability. The guiding clearance is reduced to nearly zero.

All essential components are made of hardened steel.

The workholding systems HILMA.MCP 100/125 are already prepared for the use on zero point clamping systems. For this purpose, there are location threads for retractable nipples at the bottom side of the housing.

For workholding systems HILMA.MCP, a wide range of clamping jaws is available (see data sheet WS 5.450Z).

Customised versions

HILMA.MCP workholding systems can also be delivered as customised versions. For example in other lengths or with individual mounting holes.

Please contact us.

Consultation

Our experts will be pleased to advise you also on site, and work with you to find the optimum clamping solution.

Extensive information such as drawings and CAD models are available on request.

Operation

The movable clamping jaw is displaced by a threaded spindle which is also used to build-up the clamping force.

A torque wrench is used for exact and reproducible clamping force adjustment.

*Important note

The specified clamping forces apply to a clamping height (n) of 15 mm.

For higher clamping heights, the clamping forces are reduced.

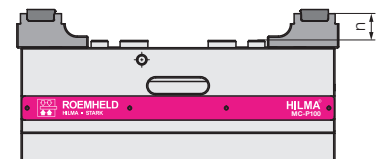

Technical data Dimensions

HILMA.MCP 60

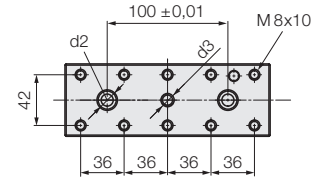
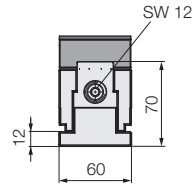
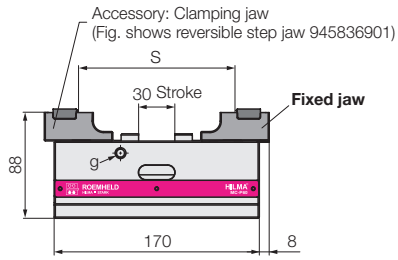

HILMA.MCP 100

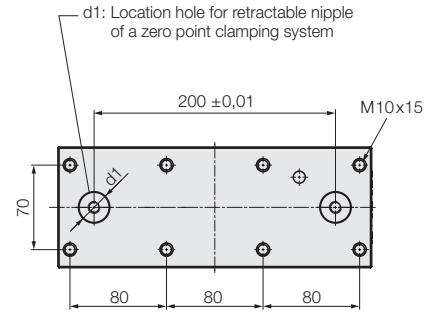
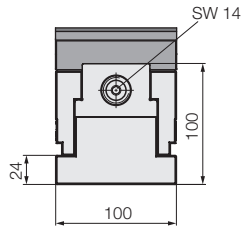
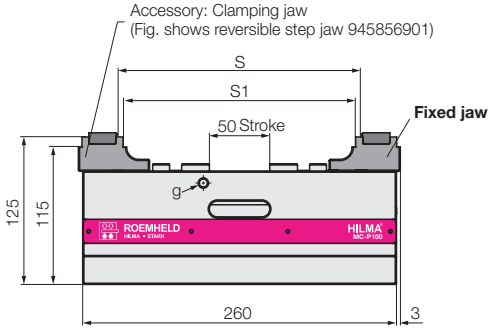

HILMA.MCP 125 K

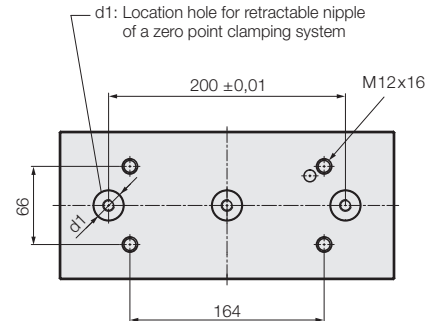
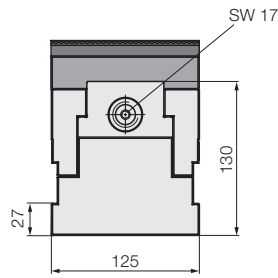
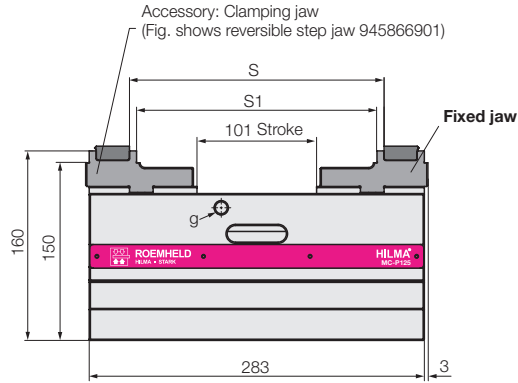

All dimensions in [mm]

Series		HILMA.MCP 60	HILMA.MCP 100	HILMA.MCP 125 K
Clamping principle		Fixed jaw	Fixed jaw	Fixed jaw
Operation		mechanical	mechanical	mechanical
Clamping force / torque	[kN/Nm]	15/60	25/90	40/180
Repetitive clamping accuracy	[mm]	±0.01	±0.01	±0.01
S*	[mm]	6–150	18–204	18–215
S1*	[mm]	–	6–192	6–203
d1	[mm]	–	25+0.01 x 5 / M10x14	25+0.01 x 5 / M10x18
d2	[mm]	10F7	–	–
d3	[mm]	M10x11	–	–
g on both sides	[mm]	M8x10	M8x14	M12x18
Weight without clamping jaws	[kg]	4.6	17.5	35.0
Part no. without clamping jaws		945830102	945850102	945860122

* depending on the used clamping jaw



Workholding Systems HILMA.MCP Z

concentric clamping, mechanically or hydraulically operated

jaw widths 60, 100 and 125 mm



Advantages

- Patented segment design
- Compact design
- High precision and accuracy of the manufactured workpieces by high rigidity
- High zero-point stability
- Sturdy design and good swarf protection
- Large jaw openings
- Extensive range of jaws
- Clamping of raw and finished parts without retrofitting
- Easy to maintain

Application

The workholding systems HILMA.MCP Z are especially advantageous for 5-axis machining. The compact design allows a good accessibility of the tools to the workpiece. Collision-free tool paths and a 5-sided workpiece machining can be achieved with short standard tools. Due to the good swarf protection, workholding systems HILMA.MCP Z are particularly suitable for the use in pallet systems. The high force and stability obviate the need for pre-stamping of the workpieces.

Accessories

- Clamping jaws and jaw inserts, accessories for mounting, positioning and operation see data sheet WS 5.450Z
- Rapid change block Quintus see data sheet WS 5.6150
- Hydraulic pressure generators on request

Application example

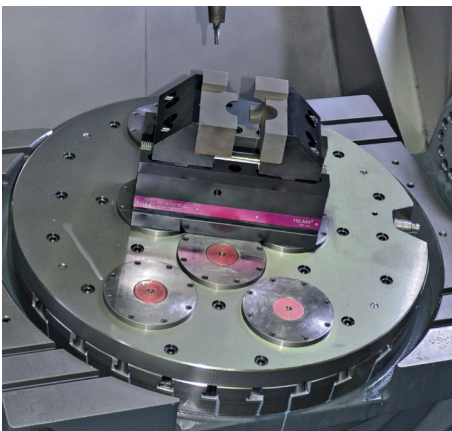

Workholding system HILMA.MCP Z with workpiece-specific base jaw and form jaw used on a 5-axis machining centre.

Description

Workholding systems of the HILMA.MCP Z series excel by a very compact design and their patented segment design.

Thanks to the adjusting spindle arranged in the upper part of the housing, deformation in the base during clamping is reduced to a minimum. Thus, a high rigidity of the workholding system is obtained.

The patented segment design ensures a high degree of precision and stability. The guiding clearance is reduced to nearly zero.

All essential components are made of hardened steel.

The workholding systems HILMA.MCP 100Z/125Z are already prepared for the use on zero point clamping systems. For this purpose, there are location threads for retractable nipples at the bottom side of the housing.

For workholding systems HILMA.MCP Z, a wide range of clamping jaws is available (see data sheet WS 5.450Z).

Consultation

Our experts will be pleased to advise you also on site, and work with you to find the optimum clamping solution.

Extensive information such as drawings and CAD models are available on request.

Customised versions

HILMA.MCP workholding systems can also be delivered as customised versions. For example with other lengths, height or with individual mounting holes.

Please contact us.

*Important note

The specified clamping forces apply to a clamping height (n) of 15 mm.

For higher clamping heights, the clamping forces are reduced.

Technical data

Clamping principle: **concentric clamping mechanically**
 Operation: **with a torque wrench hydraulically**
 with a power unit

HILMA.MCP 60 Z and ZH

Jaw width: 60 mm
 Mechanical clamping force*: 15 kN at 60 Nm
 Hydraulic clamping force*: 10 kN at 320 bar
 Clamping stroke: 30 mm
 Max. jaw opening: 6–150 mm

HILMA.MCP 100 Z and ZH

Jaw width: 100 mm
 Mechanical clamping force*: 25 kN at 90 Nm
 Hydraulic clamping force*: 20 kN at 270 bar
 Clamping stroke: 50 mm
 Max. jaw opening: 6–204 mm

HILMA.MCP 125 Z and ZH

Jaw width: 125 mm
 Mechanical clamping force*: 40 kN at 180 Nm
 Hydraulic clamping force*: 35 kN at 270 bar
 Clamping stroke: 101 mm
 Max. jaw opening: 6–400 mm

HILMA.MCP 125 ZK

Jaw width: 125 mm
 Clamping force*: 40 kN at 180 Nm
 Clamping stroke: 10 kN
 Max. jaw opening: 6–215 mm

Versions

HILMA.MCP Z mechanically operated

In the mechanically-operated version, the clamping force is built up with a threaded spindle. When operating, both clamping slides move mechanically linked to the centre of the clamping system.

A torque wrench is used for exact and reproducible clamping force adjustment.

HILMA.MCP ZH hydraulically operated

In the hydraulically-operated version, the clamping force is built up by an externally generated hydraulic pressure. When pressurising, both clamping slides move mechanically linked to the centre of the clamping system. During unclamping, the clamping slides return hydraulically to the position that had been set with adjusting screws for stroke limitation. Thus, a further unnecessary wide opening of the clamping system is avoided.

The clamping force adjustment is made by the setting of the operating pressure.

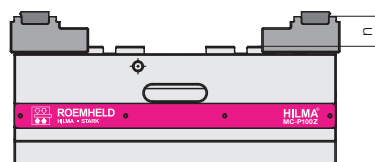

Technical data • Dimensions
mechanically operated • jaw widths 60 and 100 mm

HILMA.MCP 60 Z

Accessory: Clamping jaw
 (Fig. shows reversible step jaw 945836901)

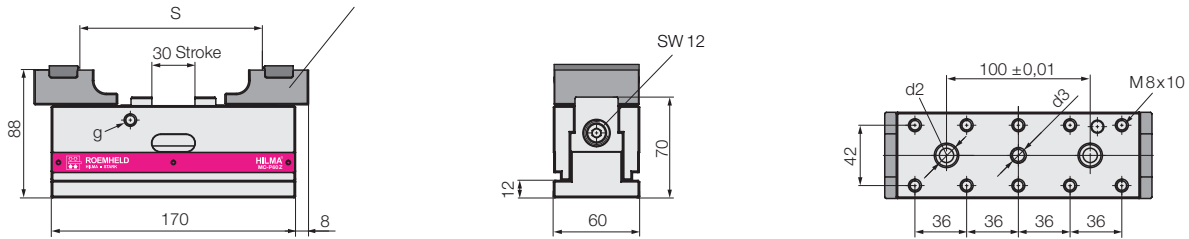

HILMA.MCP 100 Z

Accessory: Clamping jaw
 (Fig. shows reversible step jaw 945856901)

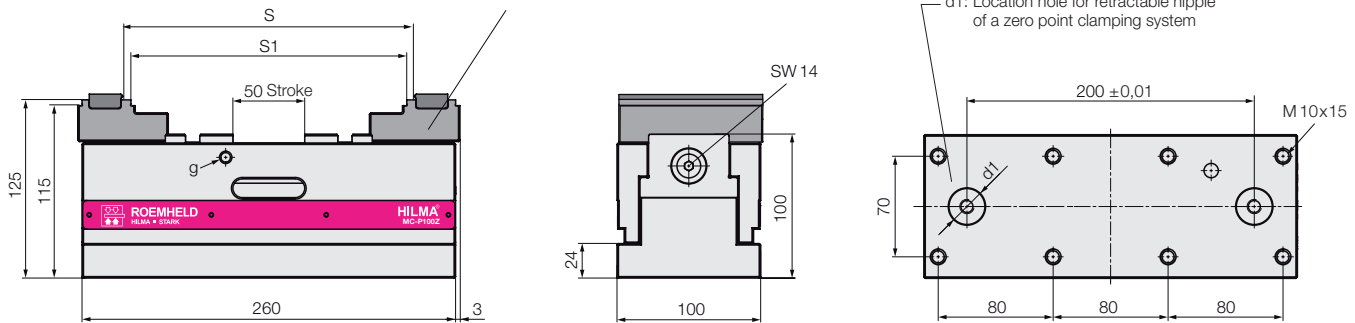

All dimensions in [mm]

Series		HILMA.MCP 60 Z	HILMA.MCP 100 Z
Clamping principle		concentric	concentric
Operation		mechanical	mechanical
Clamping force / torque	[kN/Nm]	15/60	25/90
Repetitive clamping accuracy	[mm]	± 0.015	± 0.015
S*	[mm]	6–150	18–204
S1*	[mm]	–	6–192
d1	[mm]	–	25+0.01x5 / M10x14
d2	[mm]	10F7	–
d3	[mm]	M10x11	–
g on both sides	[mm]	M8x10	M8x14
Weight without clamping jaws	[kg]	4.7	17.7
Part no. without clamping jaws		945830302	945850302

* depending on the used clamping jaw

Technical data • Dimensions
mechanically operated • jaw width 125 mm

HILMA.MCP 125 Z

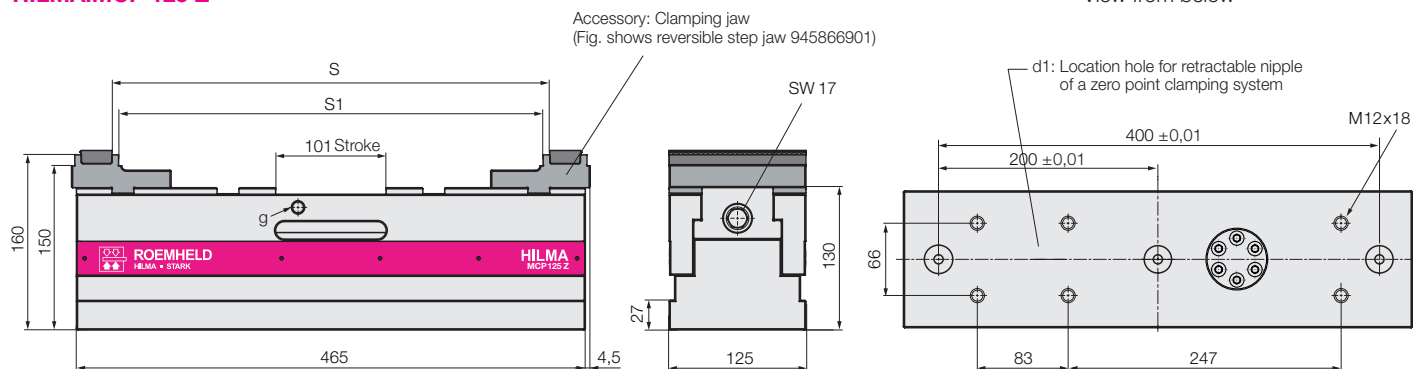

HILMA.MCP 125 ZK

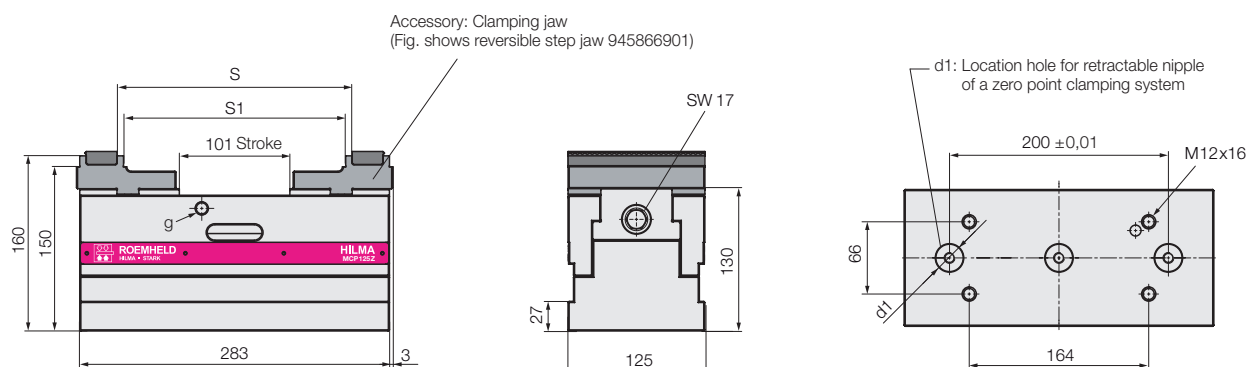

All dimensions in [mm]

Series		HILMA.MCP 125 Z	HILMA.MCP 125 ZK
Clamping principle		concentric	concentric
Operation		mechanical	mechanical
Clamping force / torque	[kN]	40/180	40/180
Repetitive clamping accuracy	[mm]	± 0.015	± 0.015
S*	[mm]	18–400	18–215
S1*	[mm]	6–388	6–203
d1	[mm]	25+0.01x5/M10x18	25+0.01x5/M10x18
g on both sides	[mm]	M12x18	M12x18
Weight without clamping jaws	[kg]	52.3	30.5
Part no. without clamping jaws		945860302	945860322

* depending on the used clamping jaw

Technical data • Dimensions

hydraulically operated • jaw widths 60, 100 and 125 mm

HILMA.MCP60 ZH

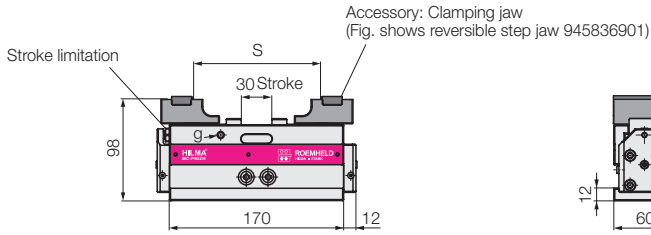

View from below

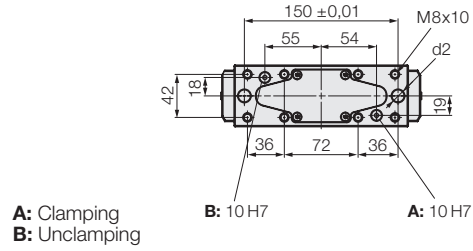

HILMA.MCP100 ZH

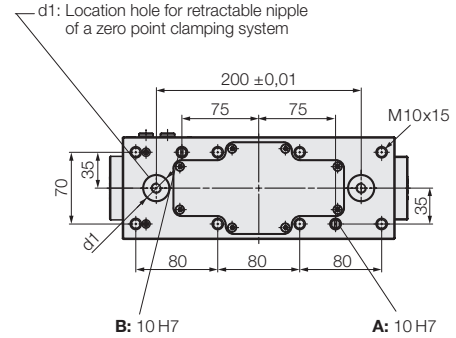
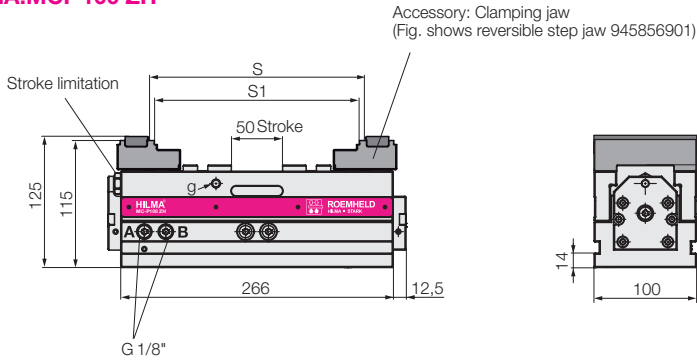

HILMA.MCP125 ZH

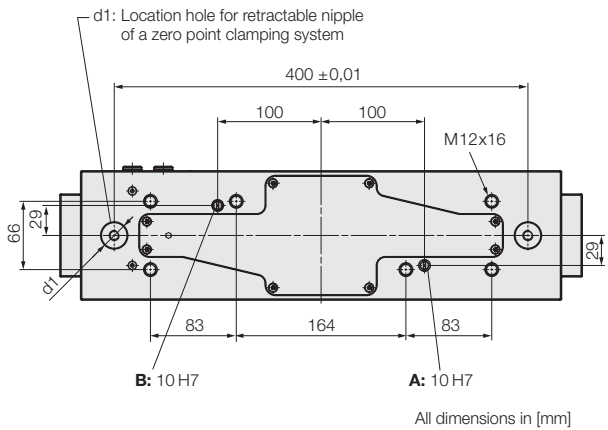
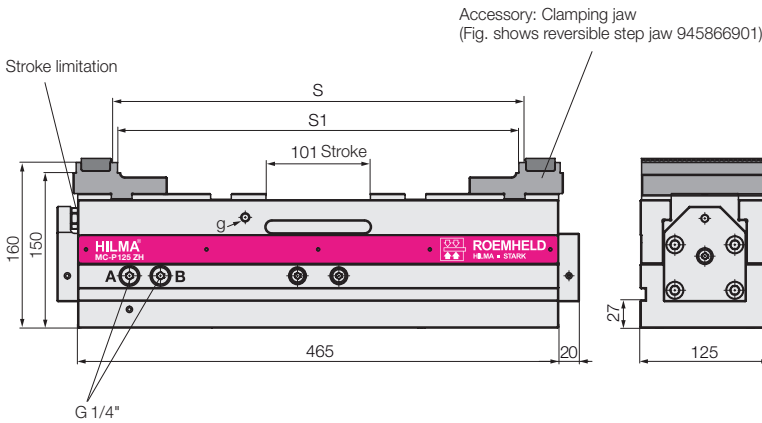

Series		HILMA.MCP60 ZH	HILMA.MCP100 ZH	HILMA.MCP125 ZH
Clamping principle		concentric	concentric	concentric
Operation		hydraulic	hydraulic	hydraulic
Clamping force / operating pressure	[kN/bar]	10/320	20/270	35/270
Max. unclamping pressure	[bar]	50	50	50
Max. oil volume	[cm ³]	15	51	161
Oil volume per 1 mm stroke	[cm ³]	0.5	1	1.6
Repetitive clamping accuracy	[mm]	± 0.02	± 0.02	± 0.02
S*	[mm]	6–150	18–204	18–400
S1*	[mm]	–	6–192	6–388
d1	[mm]	–	25+0.01 x5 / M10x14	25+0.01 x5 / M10x14
d2	[mm]	12F7	–	–
g on both sides	[mm]	M6x7	M8x11	M8x11
Weight without clamping jaws	[kg]	5.4	17.4	50.5
Part no. without clamping jaws		945830401	945850401	945860401

* depending on the used clamping jaw



Workholding Systems HILMA.MCP Z Balance

position flexible clamping, mechanically operated
 jaw widths 60, 100 and 125 mm



Advantages

- Patented segment design
- Clamping without deformation of workpieces by position flexible clamping point
- Clamping system also suitable for concentric clamping
- Compact design
- High precision and accuracy of the manufactured workpieces by high rigidity
- Sturdy design and good swarf protection
- Large jaw openings
- Extensive range of jaws
- Clamping of raw and finished parts without retrofitting
- Easy to maintain

Description

Workholding systems of the HILMA.MCP Z Balance series excel by a very compact design and their patented segment design.

Due to the position flexible function, deformation of the workpiece during clamping can be avoided.

The patented segment design ensures a high degree of precision and stability. The guiding clearance is reduced to nearly zero.

All essential components are made of hardened steel.

The workholding systems HILMA.MCP 100/125 Z Balance are already prepared for the use on zero point clamping systems. For this purpose, there are location threads for retractable nipples at the bottom side of the housing.

For workholding systems HILMA.MCP Z Balance a wide range of clamping jaws is available (see data sheet WS 5.450Z).

Customised versions

HILMA.MCP Z Balance workholding systems can also be delivered as customised versions. For example with other lengths or with individual mounting holes.

Please contact us.

Consultation

Our experts will be pleased to advise you also on site, and work with you to find the optimum clamping solution.

Extensive information such as drawings and CAD models are available on request.

Technical data

Clamping principle: **position flexible**
 Operation: **mechanically**
 with a torque wrench
 Compensation stroke: ± 2 mm

HILMA.MCP 60 ZB

Jaw width: 60 mm
 Clamping force*: 15 kN at 60 Nm
 Clamping stroke: 30 mm
 Max. jaw opening: 6–150 mm

HILMA.MCP 100 ZB

Jaw width: 100 mm
 Clamping force*: 25 kN at 90 Nm
 Clamping stroke: 50 mm
 Max. jaw opening: 6–204 mm

HILMA.MCP 125 ZB

Jaw width: 125 mm
 Clamping force*: 40 kN at 180 Nm
 Clamping stroke: 101 mm
 Max. jaw opening: 6–400 mm

Function

The workholding systems HILMA.MCP Z Balance have a floating clamping point (with released locking). After operation of the clamping spindle, first the two clamping slides concentrically approach a location-fixed workpiece position. When both clamping jaws are in contact with the workpiece, the desired clamping force is applied by means of a torque wrench. Until this moment the clamping point is still floating. If the desired clamping force is reached, the clamping point which was floating up to this moment will be safely fixed by the locking spindle.

The adaptation of the clamping point to the location-fixed workpiece position will prevent a deformation of the workpiece

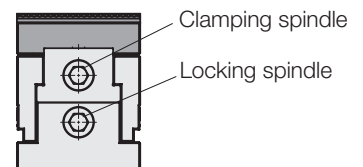

*Important note

The specified clamping forces apply to a clamping height (n) of 15 mm.

For higher clamping heights, the clamping forces are reduced.

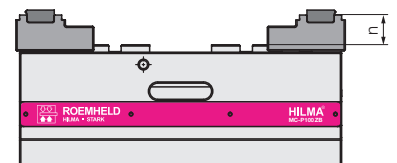

Application

Besides 5-axis machining and concentric clamping, the position flexible workholding system HILMA.MCP Balance offers the solution for individual or series clamping of bars, rails, profiles, guide rails or housings. The compensating function avoids tensioning and deformation on the workpiece.

Also workpieces that are fixed by internal contours or positioning elements can be clamped concentrically. For this purpose, customer-specific dowel holes or tapped holes can be provided in the guide bars of the HILMA.MCP Balance in which the workpiece supports or stops can be fixed.

Accessories

- Clamping jaws and jaw inserts, accessories for mounting, positioning and operation see data sheet WS 5.450Z
- Rapid change block Quintus see data sheet WS 5.6150

Application example



Clamping of aluminium bars with workholding system HILMA.MCP 100 Z Balance.

Technical data Dimensions

HILMA.MCP 60 ZB

Accessory: Clamping jaw
(Fig. shows reversible step jaw 945836901)

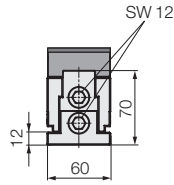
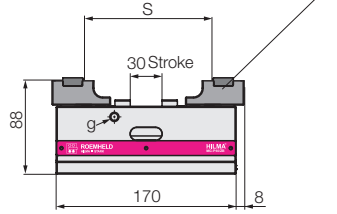

View from below

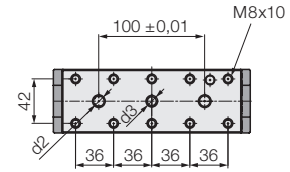

HILMA.MCP 100 ZB

Accessory: Clamping jaw
(Fig. shows reversible step jaw 945856901)

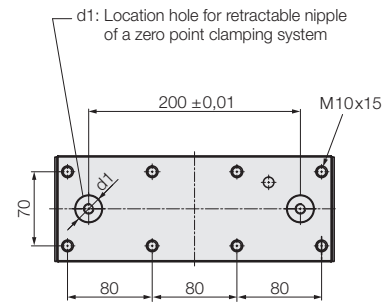
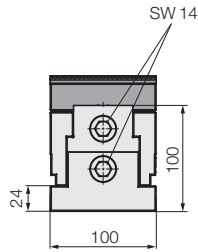
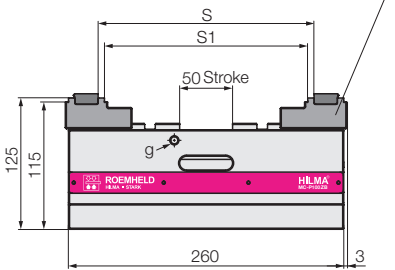

HILMA.MCP 125 ZB

Accessory: Clamping jaw
(Fig. shows reversible step jaw 945866901)

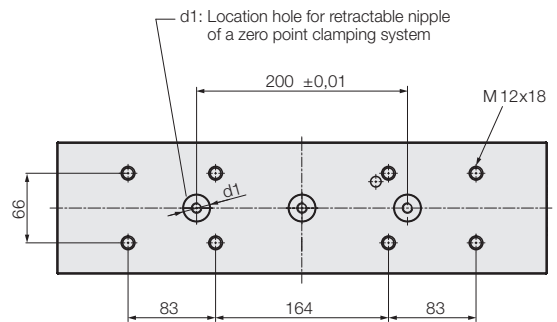
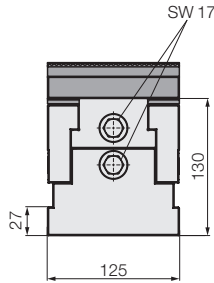
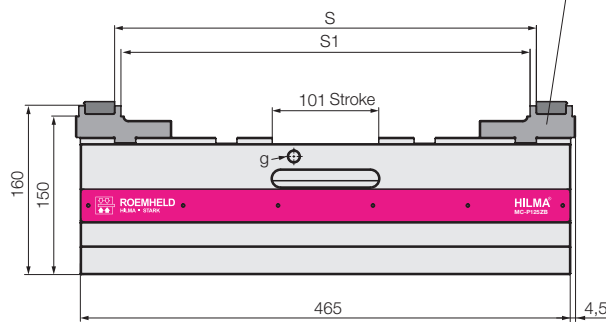

All dimensions in [mm]

Series		HILMA.MCP 60 ZB	HILMA.MCP 100 ZB	HILMA.MCP 125 ZB
Clamping principle		position flexible	position flexible	position flexible
Operation		mechanical	mechanical	mechanical
Clamping force / torque	[kN/Nm]	15/60	25/90	40/180
Repetitive clamping accuracy**	[mm]	± 0.015	± 0.015	± 0.015
Stroke, position flexible	[mm]	± 2	± 2	± 2
S*	[mm]	6–150	18–204	18–400
S1*	[mm]	–	6–192	6–388
d1	[mm]	–	25+0.01x5 / M10x14	25+0.01x5 / M10x18
d2	[mm]	10F7	–	–
d3	[mm]	M10x11	–	–
g on both sides	[mm]	M8x10	M8x14	M12x18
Weight without clamping jaws	[kg]	4.6	17.5	52.3
Part no. without clamping jaws		945830702	945850702	945860702

* depending on the used clamping jaw

** with closed locking

Accessories for Workholding Systems HILMA.MCP

Clamping jaws and jaw inserts,
accessories for mounting, positioning and operation

Clamping jaws / jaw inserts

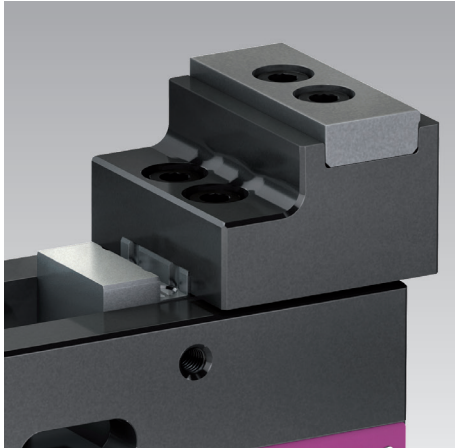

Scope of delivery - clamping jaws

All clamping jaws are supplied with fixing screws.
Reversible step jaws are always delivered without jaw inserts.
They are to be ordered separately as accessories (see page 3).

Important notes

- By the use of clamping jaws with grip jaw inserts, the jaw opening is reduced by approx. 4 mm.
- Technical information and application recommendations for jaw inserts see page 3
- All HILMA.MCP workholding systems are delivered without clamping jaws.
 1. Selection: clamping jaws
 2. Selection: jaw inserts (see page 3)
- Reversible step jaws for jaw inserts can only be used in combination with the appropriate jaw inserts.

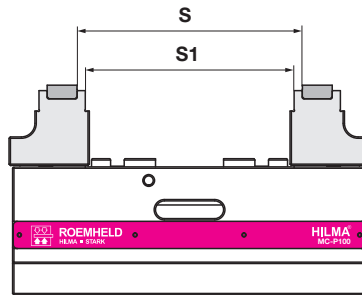
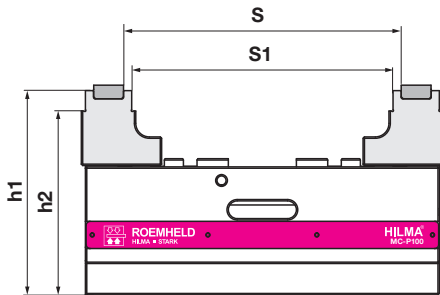

S: Clamping range
step at the jaw insert
S1: Clamping range
step at the jaw body

h1: Height of support
step at the jaw insert
h2: Height of support
step at the reversible step jaw

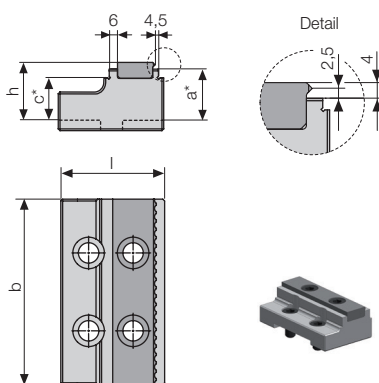

Reversible step jaws, flat for 1 jaw insert hardened and ground

Type	Part no.	Dimensions					Clamping range		Height of support	
		l	b	h	a	c	S	S1	h1	h2
MCP 60	945836901	56	60	22	18	-	12-126	-	88	-
MCP 60 ZH	945836901	56	60	22	18	-	12-126	-	98	-
MCP 100	945856901	59	100	29	25	15	18-204	6-192	125	115
MCP 125	945866901	91	125	34	30	20	18-400	6-388	160	150
MCP 125 Compact	945866901	91	125	34	30	20	18-215	6-203	160	150

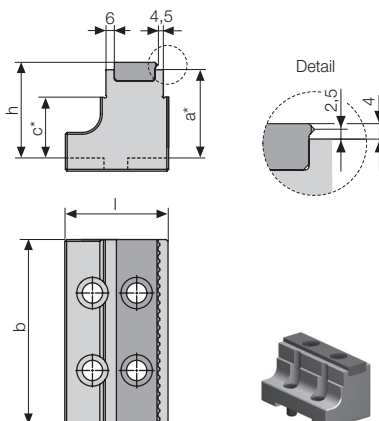

Reversible step jaws for 1 jaw insert hardened and ground

Type	Part no.	Dimensions					Clamping range		Height of support	
		l	b	h	a	c	S	S1	h1	h2
MCP 60	945836902	56	60	34	30	-	12-126	-	100	-
MCP 60 ZH	945836902	56	60	34	30	-	12-126	-	110	-
MCP 100	945856902	59	100	54	50	35	18-204	6-192	150	135
MCP 125	945866902	91	125	66	62	42	18-400	6-388	192	172
MCP 125 Compact	945866902	91	125	66	62	42	18-215	6-203	192	172

* Tolerance ±0.01 mm
All dimensions in [mm]

Accessories Clamping jaws

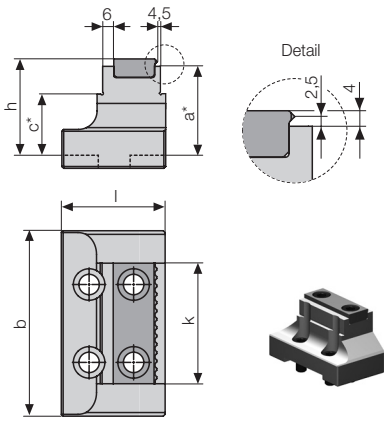

Reversible step jaws for 1 jaw insert hardened and ground, various widths

Type	Part no.	Dimensions						Clamping range		Height of support	
		l	b	h	a	c	k	S	S1	h1	h2
MCP 60	945836903	56	60	34	30	-	35	12-126	-	100	-
MCP 60 ZH	945836903	56	60	34	30	-	35	12-126	-	110	-
MCP 100	945856903	59	100	54	50	35	65	18-204	6-192	150	135
MCP 125	945866903	91	125	66	62	42	80	18-400	6-388	192	172
MCP 125 Compact	945866903	91	125	66	62	42	80	18-215	6-203	192	172

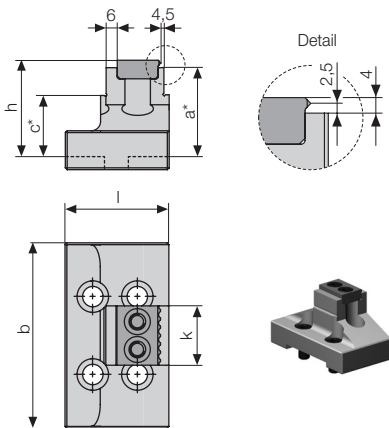

Reversible step jaw for 1 jaw insert hardened and ground, various widths

Type	Part no.	Dimensions						Clamping range		Height of support	
		l	b	h	a	c	k	S	S1	h1	h2
MCP 100	945856904	59	100	54	50	35	32	18-204	6-192	150	135

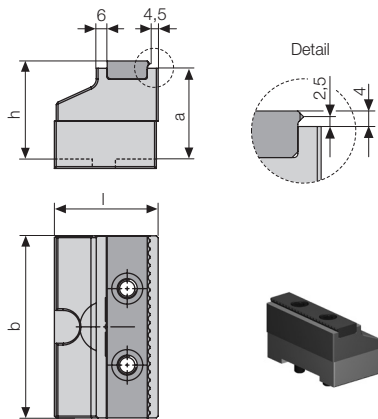

Pendulum jaws for 1 jaw insert hardened and ground

Type	Part no.	Dimensions				Clamping range S	Height of support h1
		l	b	h	a		
MCP 100	945856905	56	100	54	50	12-204	150
MCP 125	945866905	88	125	66	62	12-400	192
MCP 125 Compact	945866905	88	125	66	62	12-215	192

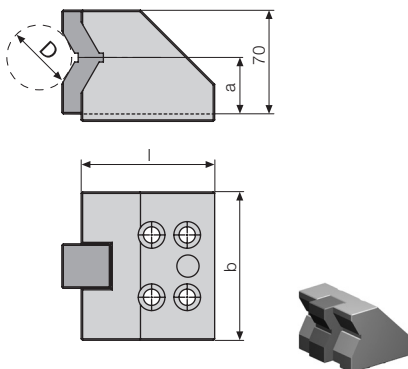

Vee jaws with horizontal prism with interchangeable insert, hardened

Type	Part no.	Dimensions			Clamping range D	Clamping centre h1
		l	b	a		
MCP 60	945836921	60	60	40	D 10-76	110
MCP 60 ZH	945836921	60	60	40	D 10-76	120
MCP 100	945856921	90	100	38	D 12-80	138

Vee jaws with vertical prism on request

* Tolerance ± 0.01 mm
All dimensions in [mm]

Accessories

Clamping jaws / jaw inserts

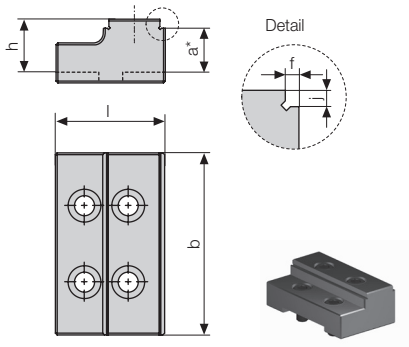

Reversible jaws with step hardened

Type	Part no.	Dimensions						Clamping range S	Height of support h1
		l	b	h	a	f	j		
MCP 60	945836931	49	60	23	18	3	5	6-150	88
MCP 60 ZH	945836931	49	60	23	18	3	5	6-150	98
MCP 100	945856931	60	100	30	25	3	5	6-204	125
MCP 125	945866931	80	125	35	30	5	5	6-400	160
MCP 125 Compact	945866931	80	125	35	30	5	5	6-215	160

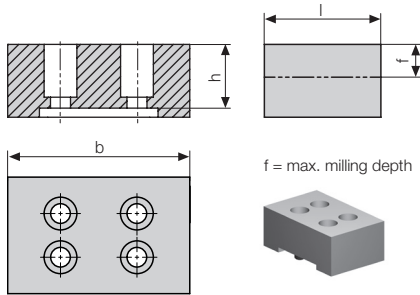

Block jaws, soft for milling workpiece contours

Type	Part no.	Dimensions			
		l	b	h	f
MCP 60	945836932	42	60	25	8
MCP 100	945856932	64	100	35	18
MCP 125	945866932	88	125	55	32
MCP 125 Compact	945866932	88	125	55	32

* Tolerance ±0.01 mm
All dimensions in [mm]

Interchangeable jaw inserts

see also: data sheet WS 12-SE Technical information "Jaw inserts for clamping jaws"

Jaw inserts grip serrated



Grip/smooth

Jaw inserts with coatings



Grip round

Hard metal coarse/smooth
Hardness 58 HRC
Grain size 0.3 – 0.5 mm

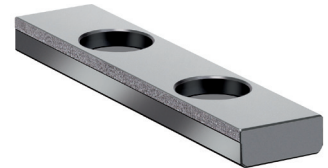

TUC/smooth
Hardness 80 HRC
Coarseness RA 10

Recommendation for jaw inserts to increase the retention forces

Workpiece material	Workpiece surface	Workpiece surface				
		rolled / cast / forged	drawn	sawn	milled	ground
Steel, e.g. C45, 20MnCr5, 31CrMoV9		HM coarse, Grip	TUC	HM coarse, Grip	TUC	TUC
Heat-treated steel e.g. C45 induction-hardened, 20 Mn Cr 5 case-hardened, 31 Cr Mo V9 nitrided					TUC	TUC
Cast e.g. GG, red bronze		HM coarse, Grip			TUC	TUC
Titanium			TUC		TUC	TUC
Aluminium		HM coarse, Grip		Grip		TUC
Non-ferrous metals				Grip		TUC

Part numbers

Type	Part no.	Part no.	Part no.
MCP 60	Jaw width 60	Jaw width 35	
Jaw inserts Grip/smooth	550500543	550500545	
Jaw inserts HM coarse/smooth	550500635	550500740	
Jaw inserts TUC/smooth	550500743	550500744	
MCP 100	Jaw width 100	Jaw width 65	Jaw width 32
Jaw inserts Grip/smooth	550500542	550500471	550500470
Jaw inserts HM coarse/smooth	550500523	550500723	550500741
Jaw inserts TUC/smooth	550500586	550500745	550500746
Jaw inserts Grip round with fixing screw	932856001		
MCP 125	Jaw width 125	Jaw width 80	
Jaw inserts Grip/smooth	550500509	550500547	
Jaw inserts HM coarse/smooth	550500660	550500742	
Jaw inserts TUC/smooth	550500747	550500748	
Jaw inserts Grip round with fixing screw	932856003		

Accessories for mounting, positioning and operation

Mounting and positioning

Centring bolts for hub centring on machine table



Type	Part no.	Ø [mm]	L [mm]
Quintus 1/2/3	961535001	D30 g6	15/38
	961535002	D32 g6	15/38
	961535003	D50 g6	25/48
	961535009	D50 g6	18/41

Retractable nipples for mounting at the clamping system



Type	Part no.	Quantity
Quintus 1 / MCP 60	939200201	1 off
Quintus 2 / MCP 100	939200202	1 set = 2 off
Quintus 3 / MCP 125	939200203	1 set = 3 off

Positioning pins stepped for grid plate, set of 2 off



Type	Part no.	Ø [mm]
MCP 60	939200101	10/12
MCP 100 / MCP 125	939200103	25/12

Clamping claws 1 set = 4 off, incl. screws

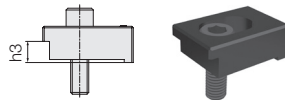

Type	Part no.	Thread	h3 [mm]
MCP 60	937772031	M10	12
MCP 60	937772041	M12	12
MCP 100	937772011	M12	24
MCP 100 ZH	937772061	M12	14
MCP 125	937773011	M12	27
MCP 125	937773021	M16	27

Key block with screw for Quintus 1,2,3



Part no.		Slot [mm]
961535004	DIN 6322, 1 off	14

T-nut with screw for Quintus 1,2,3



Part no.		Slot [mm]
961535005	DIN 508, 4 off	14

Operation

Torque wrenches



Type	Part no.	Torque [Nm]
MCP 60	937926600	5 – 60
MCP 100	937926610	20 – 120
MCP 125	937926620	40 – 200

Sockets for torque wrenches



Type	Part no.	SW
MCP 60	131240021	12
MCP 100	131240020	14
MCP 125	131240017	17

Allen wrenches for fixing screws and jaw inserts



Type	Part no.	SW
MCP 60	169110002	6
MCP 100	169110003	8
MCP 125	169110005	10

T-nuts DIN 508, 1 set = 4 off

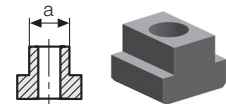

Type	Part no.	Thread	Width a
MCP 60	937773002	M10	12
MCP 60	937773003	M10	14
MCP 60/MCP 100	937773004	M12	18
MCP 125	937773231	M12	18
MCP 125	937773311	M16	18

Hydraulic connection

Plug-in connector for hydraulic connection from below including seals, 1 off

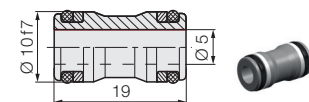

Part no.	for bore hole
805300023	Ø 10 H7 x 10 mm deep

More Information.

You want to know more about our products & services?
Please visit our websites.



STARK Spannssysteme GmbH
www.stark-roemheld.com



ROEMHELD Group
www.roemheld.de

In the download center you will find among others

- ▶ Brochures
- ▶ Catalogs
- ▶ Operating instructions
- ▶ Functional videos



ROEMHELD
HILMA ■ STARK

HILMA MACHINE VICES CAN BE PERFECTLY COMPLEMENTED AND COMBINED WITH STARK ZERO POINT CLAMPING SYSTEMS.

USE SYNERGIES

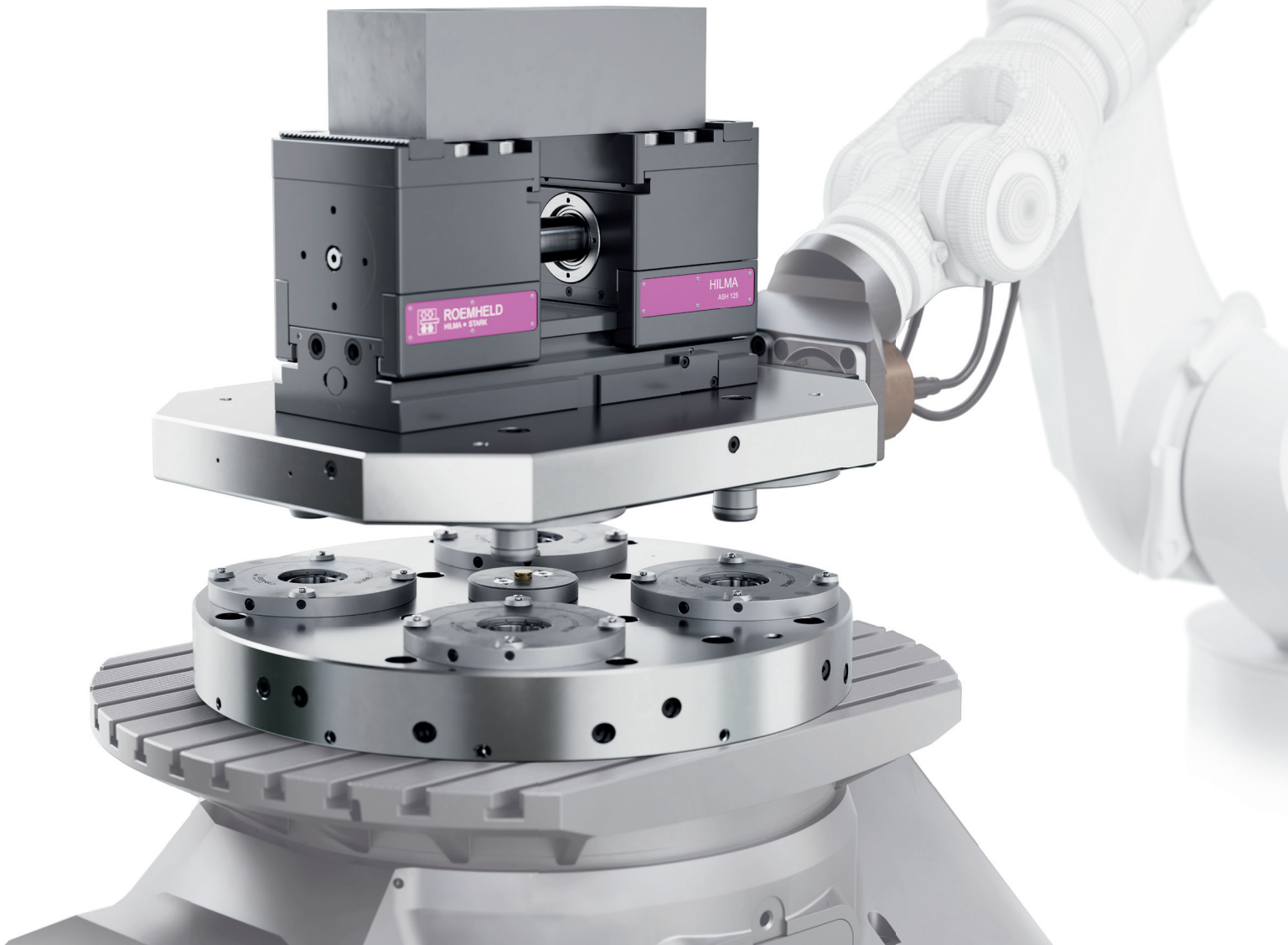

- ▶ HILMA.ASH automated workholding system on zero point clamping system
- ▶ Fast closing plate with 4 elements STARK.classicNG.2 Twister and media duct for clamping/releasing the vice
- ▶ Coupling unit with zero-point clamping system (device pallet - handling system) 2 elements STARK.airtec with integrated query

A COMPANY OF THE
ROEMHELD GROUP

STARK

Spannsysteme

The ROEMHELD Group consists of 5 companies at locations in Germany and Austria, each with different products and orientations. With numerous subsidiaries, sales partners and service companies on all continents and in more than 50 countries, rapid and intensive customer support is provided in the mechanical engineering, medical technology, automotive, aviation and agricultural industries.

As part of the ROEMHELD Group, STARK benefits from the security and experience of a family-run traditional company as well as from the worldwide sales and service network. At the same time, this background provides the independence to pursue dynamic and innovative goals for new market-driven developments and customer-specific solutions with which STARK maintains its leading technological position.



ROEMHELD
HILMA ■ STARK

STARK Spannsysteme

A company of the ROEMHELD Group

STARK Spannsysteme GmbH
Römergrund 14 | 6830 Rankweil
Austria

+43 5522 37 400 - 0
info@stark-roemheld.com

stark-roemheld.com